

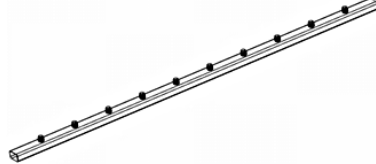





100 Series AFCO-Rail Level Rail



INSTALLATION INSTRUCTIONS

PARTS INCLUDED:			
TOP RAIL WITH CONNECTORS (1)		BOTTOM RAIL WITH CONNECTORS (1)	
A		B	
SADDLE BRACKET (2)	BRACKET COVER (2)	BOTTOM BRACKET (2)	10" SUPPORT BLOCK (1)
C		D	
E		F	
SUPPORT BLOCK CONNECTOR (2)	#10x1" SELF DRILLING SCREW (12)	3 1/2" SQUARE DRIVER BIT (1)	ADHESIVE TAB (1)
G		H	
I		J	

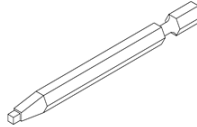
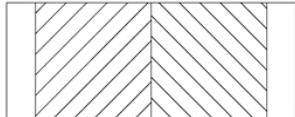
100 SERIES AFCO-RAIL LEVEL RAIL

TOOLS REQUIRED:

Drill bit 5/32" (.156")
 Drill (with adjustable clutch, recommended)
 Miter Saw (with metal cutting blade)
 Level
 Rubber mallet
 Tape measure
 Touch-up paint

NOTES:

- Post and balusters packaged separately.
- An AFCO-Tool is available to simplify the locating, pre-drilling and installation of brackets.

FOR A SUCCESSFUL INSTALLATION:

- Read the instructions completely before beginning the installation.
- Plan your railing project. Sketch your project with the actual measurements of your deck or balcony complete with post locations.
- Check local building codes to ensure compliance.
- Check carton(s) to determine part count is complete.
- After cutting rails, balusters, or posts, paint exposed metal for maximum protection against the elements.
- Installation is best accomplished with two people.
- Wear personal protection equipment; safety glasses, etc.
- Use care not to over-torque the screws. Pre-drilling is recommended.
- **Provided hardware to install AFCO-Rail is for use with Aluminum AFCO-Rail posts. If installing to other surfaces the installer must acquire the appropriate hardware as needed for proper installation.**

POSTS INSTALLATION:

1. Measure and locate the position of the post(s) based on the project layout.

2. Install the post by attaching the aluminum mounting flange to the surface of the deck or balcony. Position the post so the fastener will go into the floor joist, and make sure the decking is firmly attached to the joist at the location of the post. If necessary, use wood blocking as reinforcement underneath the decking where the posts are located. Post mounting fasteners should be able to secure into the joist or reinforcement braces, not just the decking itself. When installing AFKO-Rail Post on top of a wood surface, screws must be lagged into at least 3" of solid wood. Deck boards sized 5/4" or 1 1/2" do not provide sufficient material for a safe installation.

Note: When installing AFKO-Rail Post onto treated wood surface, install the provided ACO pad (included in the post kit) between the post base and the treated surface.

3. Position the post to the deck surface. Four 3/8" diameter mounting holes are provided on the mounting flange. Mark the mounting flange hole locations and remove the post. Drill the marked locations into the decking and reinforcement. Remount the post. Insert the appropriate fasteners to secure the mounting flange to the deck structure.

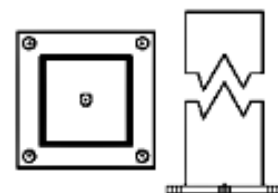

4. Finish by sliding the base trim to the bottom of the post to cover the mounting flange.

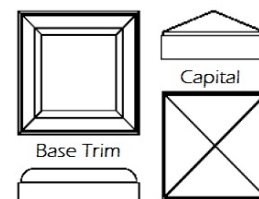

5. To install the post cap, set post capital in place on top of the post and tap lightly with a rubber mallet to drive the post cap onto the post. Silicone or water based caulking may be used to secure the post cap and base trim.

LEVEL RAIL INSTALLATION:

1. Carefully measure the opening between posts or walls and calculate the length of rail that needs to be cut. Divide the trim length amount in half, and starting with the bottom rail (B), transfer and mark the measurement to each end of the rail. For the sake of baluster spacing or personal preference, all of the trim length could be cut from one end of both rails. Make this determination before cutting the rails. Always refer to local building code requirements to determine the baluster spacing requirements in your area (4" maximum is typical). Carefully cut the rail. Mark top rail (A) and cut. For clearance purposes the top rail is precut 3/4" shorter than the bottom rail.

2. Install support block connectors (G) using self-drilling screws (H) to the underside of bottom rail (B). The support block will be installed in step 11.

Note: One support block, cut from support block material (F), is recommended for rails measuring 72" in length or less; two support blocks for longer lengths. If one support block is required, install the support block connector (G) at center point of bottom rail (B). If two support blocks are required, install support block connectors (G) equal distance from each end of the bottom rail (B).

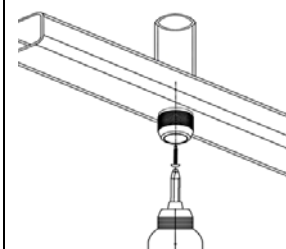

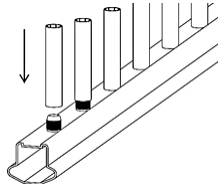
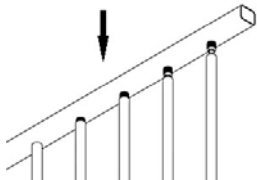
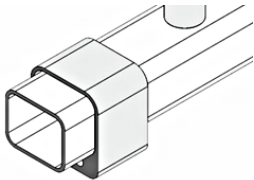
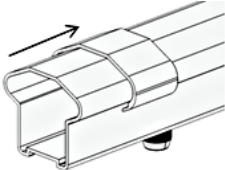
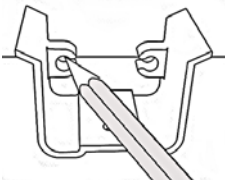
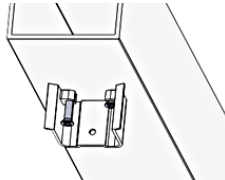
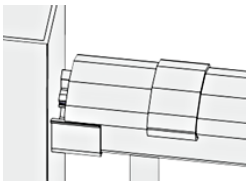
<p>3. To assemble rail, begin with top rail (A) and insert balusters over pre-installed connectors. Firmly tap each baluster with a rubber mallet to ensure the baluster is fully seated against the top rail. <i>Note: It is recommended to use the box as a pad to prevent scuffing of the painted finish. If installing square balusters, make sure they are properly seated in the slot on the underside of the top rail to prevent twisting.</i></p>	
<p>4. Attach balusters to bottom rail (B) beginning at one end and working to opposite end. Stand the assembly upside down on the surface of the box and firmly tap the bottom rail with a rubber mallet to secure the balusters in place. Stand assembly upright. <i>Note: Notches are provided on the front of the box to help align balusters and aid in the assembly of the rail in this step.</i></p>	
<p>5. Slide bottom brackets (E) with screw holes down and counter bore holes facing toward the balusters, over each end of the bottom rail (B).</p>	
<p>6. Slide bracket covers (D) at least 3-4 inches inward over each end of the top rail (A). A small piece of tape may be needed to hold the bracket covers in place.</p>	
<p>7. Measure up 34 1/2" (36" rail height) or 40 1/2" (42" rail height) from the floor and mark a level, horizontal line on the post or wall. <i>Note: This measurement may vary by local code or personal preference.</i></p>	
<p>8. Align screw holes in saddle bracket (C) on the horizontal line making certain the saddle bracket (C) is centered on the post. Mark screw locations. Repeat process at opposite end.</p>	
<p>9. Attach both saddle brackets (C) with self-drilling screws (H) at the marked screw locations completed in Step 8. Pre-drilling is recommended.</p>	
<p>10. Set the rail assembly into the saddle brackets (C) letting the bottom rail hang freely between the posts. <i>Note: Check for level.</i></p>	

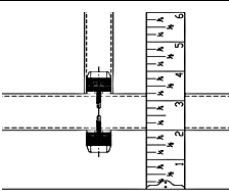
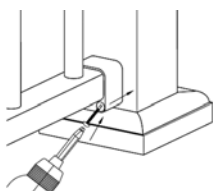
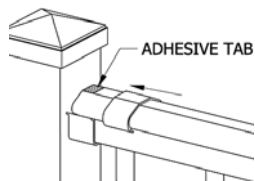
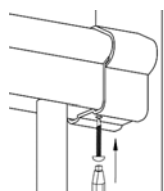
<p>11. At the point(s) where you installed support block connectors (step 2), carefully measure the distance from the underside of the bottom rail (B) to the floor. Cut support block material (F) to fit. Remove rail assembly from the saddle brackets (C). Slip support blocks over support block connectors (G). Slide the rail back into place and make certain the rail is plumb.</p>	
<p>12. Slide and hold the bottom bracket (E) firmly against the post or wall. Secure the bracket with self-drilling screws (H). Repeat the process at the other side. <i>Note: Screw holes in bracket (E) are angled to make mounting the brackets easier.</i></p>	
<p>13. Apply adhesive tab (J) to flat, top surface of top rail (A), near the post. Slide bracket cover (D) to interlock with flange on the saddle bracket (C).</p>	
<p>14. Screw self-drilling screws (H) into the top rail (A) from the underside of each saddle bracket (C) through the provided locating hole to securely fasten the rail.</p>	

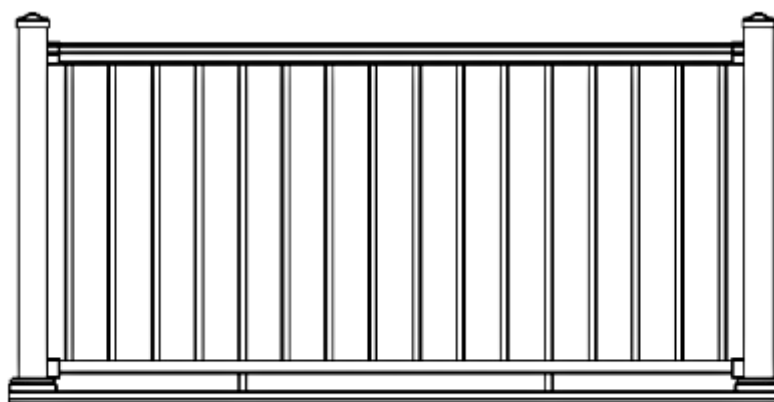







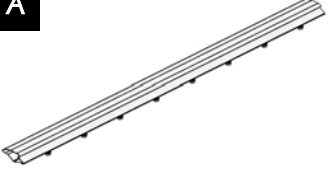

Installed View

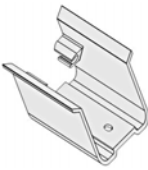
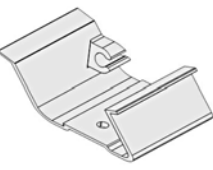
100 Series AFco-Rail Fixed Stair Rail

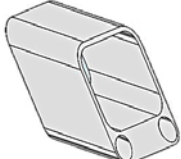
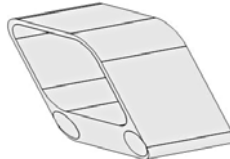

INSTALLATION INSTRUCTIONS

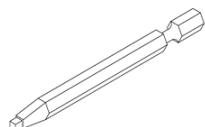
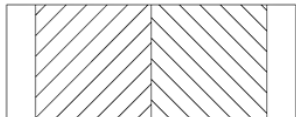
PARTS INCLUDED:			
TOP RAIL WITH CONNECTORS (1)	BOTTOM RAIL WITH CONNECTORS (1)	UPPER SADDLE BRACKET (1)	LOWER SADDLE BRACKET (1)
A 	B 	C 	D 
BRACKET COVERS (2)	UPPER BOTTOM BRACKET (1)	LOWER BOTTOM BRACKET (1)	10" SUPPORT BLOCK (1)
E 	F 	G 	H 
SUPPORT BLOCK CONNECTOR (2)	#10 SELF DRILLING SCREWS	3 1/2" SQUARE DRIVER BIT (1)	ADHESIVE TAB (1)
I 	J 1" - 4 each 1-1/2" - 8 each 	K 	L 

100 SERIES AFco-RAIL FIXED STAIR RAIL

TOOLS REQUIRED:

Drill bit 5/32" (.156")
 Drill (with adjustable clutch, recommended)
 Miter Saw (with metal cutting blade)
 Level
 Rubber mallet
 Tape measure
 Touch-up paint

NOTES:

- Post and balusters packaged separately.
- An AFco-Tool is available to simplify the locating, pre-drilling and installation of brackets.

FOR A SUCCESSFUL INSTALLATION:

- Read the instructions completely before beginning the installation.
- Plan your railing project. Sketch your project with the actual measurements of your deck or balcony complete with post locations.
- Check local building codes to ensure compliance.
- Check carton(s) to determine part count is complete.
- After cutting rails, balusters, or posts, paint exposed metal for maximum protection against the elements.
- Installation is best accomplished with two people.
- Wear personal protection equipment; safety glasses, etc.
- Use care not to over-torque the screws. Pre-drilling is recommended.
- **Provided hardware to install AFco-Rail is for use with Aluminum AFco-Rail posts. If installing to other surfaces the installer must acquire the appropriate hardware as needed for proper installation.**

POSTS INSTALLATION:

1. Begin by determining where the top and bottom post will be located. Mark the desired location of the post.
Note: To ensure post location is compatible with railing, prior to securing to the deck surface, place both posts in position, and lay the bottom rail along the stair-nosing from top to bottom adjacent to both post. On the rail side of the post, measure up from the top of the rail and ensure there is a minimum of 34" for the 36" rail height and a minimum of 40" for the 42" rail height to the top of the post. Post location may have to be adjusted to ensure minimum is obtained. Repeat this step for the bottom post.

- For railing mounted 36" high use a 44" post at the bottom of the stairs.
- For railing mounted 42" high use a 54" post at the bottom of the stairs.

For a wooden deck position the post so the fasteners will go into the floor joists, and make sure the decking is firmly attached to the joists at the location of the posts. If necessary, use wood blocking as reinforcement underneath the decking where the posts are located. Fasteners which hold the brackets to the surface should be able to secure to joist or reinforcement braces, into at least 3" of solid wood.



2. When the final position is determined for the post, mark the hole locations of the four 3/8" diameter mounting holes provided on the base and remove the post assembly. Drill the marked locations into the decking and reinforcement using the proper size drill required for the fasteners being used.



3. Remount the post assembly. Insert the appropriate fasteners then secure the base to the deck structure. Make certain the posts are plumb. If the post requires adjustment, add stainless steel washers under the base plate. Do not install the base post trim and post capitals until step 4 of the rail installation.
Note: When installing AFKO- Rail Post onto treated wood surface, install the provided ACQ pad that is included in the post kit between the post base and the treated surface.

FIXED RAIL INSTALLATION:

1. Lay the bottom rail (B), with baluster connectors facing up and centered between the posts, on the stair nosing from top to bottom, adjacent to the posts and mark a line on the rail from the inside of each post (1). Also, make a reference mark on the bracket side of both posts at the point where the top of the rail meets the post (2).
Note: This reference mark will be used to locate saddle brackets in step 5.

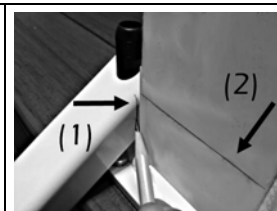

2. Place the top rail (A) next to the bottom rail (B), align the baluster connectors and duplicate the marks from the bottom rail cut line onto the top rail. Now mark the top rail 5/8" shorter on each end; this is the cut line for top rail. Only the top rail is cut 5/8" shorter on each end.









3. Cut the rails along the marked lines.

4. Install the base post trim on the upper and lower posts.

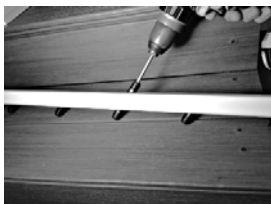
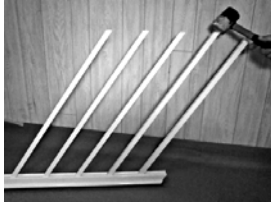
5. To install the saddle bracket (C&D) on both upper and lower post, measure and mark a level line up from the reference marks, previously completed in step 1. Mark 31" for 36" railing or 37" for 42" rail.

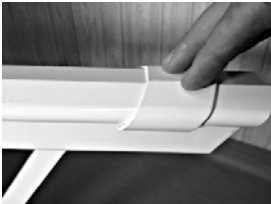

<p>6. Align screw holes in the upper and lower saddle brackets (C&D) on the marked lines. Make sure the brackets are centered on the posts. Mark the screw hole locations with a pencil.</p>	
<p>7. Attach saddle brackets (C&D) with 1-1/2" self-drilling screws (J) at the marked screw locations in Step 6. Pre-drilling is recommended.</p>	
<p>8. Install support block connectors (I) using 1" self-drilling screw (J) to the underside of bottom rail (B). <i>Note: One support block, cut from support block material (H), is recommended for rails measuring 72" in length or less; two support blocks for longer lengths. If one support block is required, install support block connector (I) at center point of bottom rail (B). If two support blocks are required, install support block connectors (I) equal distance from each end of the bottom rail (B).</i></p>	
<p>9. To assemble rail, begin with top rail (A) and insert balusters over pre-installed connectors. Use a rubber mallet to tap the balusters into place. <i>Note: It is recommended to use the box as a pad to prevent scuffing of the painted finish. If installing square balusters, make sure they are properly seated in the slot on the underside of the top rail to prevent twisting.</i></p>	
<p>10. Attach balusters to bottom rail (B) beginning at one end and working to the opposite end. Stand the assembly upside down on the surface of the box and tap the bottom rail with a rubber mallet to secure the balusters in place. Stand assembly upright. <i>Note: Notches are provided on the front of the box to help align balusters and aid in the assembly of the rail in this step.</i></p>	
<p>11. Slide bracket covers (E) at least 3-4" inward over each end of the top rail (A) so the angle of the cover matches the angle of the top rail. <i>Note: A small piece of tape may be required to hold the bracket covers in place.</i></p>	
<p>12. Slide bottom brackets (F&G) with the counter bore holes facing down and toward the balusters, over each end of the bottom rail (B). A small piece of tape may be required to hold lower bottom brackets in place. Next, set the rail assembly into the saddle brackets (C&D) letting the bottom rail hang freely between the posts. <i>Note: May use option (not shown) to install brackets with holes facing up based on customer preference and accessibility.</i></p>	
<p>13. At the point(s) where you installed support block connectors (step 8), carefully measure the distance from the underside of the bottom rail (B) to the floor. Cut support block material (H) to fit. Slip support blocks over support block connectors (I). Slide the rail back into place and make certain the rail is plumb.</p>	

14. Slide and hold the upper bottom bracket (F) firmly against the top post. Secure the bracket with 1-1/2" self-drilling screws (J). Repeat the process securing lower bottom bracket (G) to the bottom post using 1-1/2" self-drilling screws (J).
Note: Screw holes in brackets (F&G) are angled to make mounting the brackets easier.

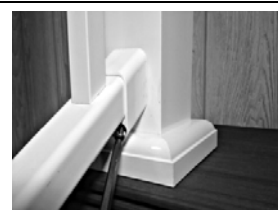

15. Apply adhesive tab (L) to flat, top surface of top rail (A), near the post. Slide bracket covers (E) to interlock with flange on the saddle brackets (C&D).

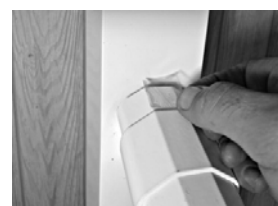

16. Screw 1" self-drilling screws (J) into the top rail (A) from the underside of saddle brackets (C&D) through the provided locating hole.



This photo depicts a fully assembled rail section of AFCO-Rail 100 Series Fixed Stair Rail installed between two posts on a standard set of steps.







200 Series AFco-Rail Level Rail

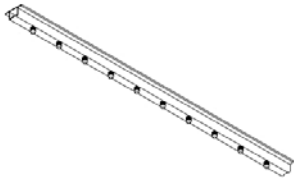
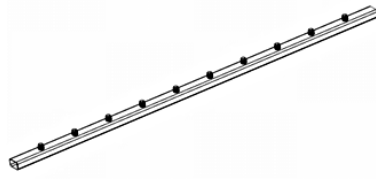

INSTALLATION INSTRUCTIONS

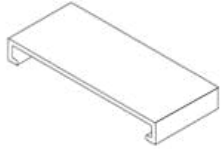
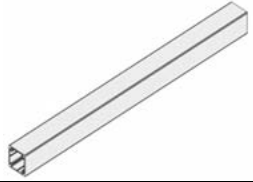
PARTS INCLUDED:

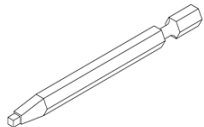
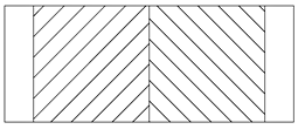
TOP RAIL WITH CONNECTORS (1)		BOTTOM RAIL WITH CONNECTORS (1)	
A		B	
SADDLE BRACKET (2)	BOTTOM BRACKET (2)	TOP RAIL CAP (2)	10" SUPPORT BLOCK (1)
C		D	
E		F	
SUPPORT BLOCK CONNECTOR (2)	#10x1" SELF DRILLING SCREW (12)	3 1/2" SQUARE DRIVER BIT (1)	ADHESIVE TAB (1)
G		H	
I		J	

NOTE: Post and balusters packaged separately.

TOOLS REQUIRED:

Drill bit 5/32" (.156")
 Drill (with adjustable clutch, recommended)
 Miter Saw (with metal cutting blade)
 Level
 Rubber mallet
 Tape measure
 Touch-up paint

FOR A SUCCESSFUL INSTALLATION:

- Read the instructions completely before beginning the installation.
- Plan your railing project. Sketch your project with the actual measurements of your deck or balcony complete with post locations.
- Check local building codes to ensure compliance.
- Check carton(s) to determine part count is complete.
- After cutting rails, balusters, or posts, paint exposed metal for maximum protection against the elements.
- Installation is best accomplished with two people.
- Wear personal protection equipment; safety glasses, etc.
- Use care not to over-torque the screws. Pre-drilling is recommended.
- **Provided hardware to install AFco-Rail is for use with Aluminum AFco-Rail posts. If installing to other surfaces the installer must acquire the appropriate hardware as needed for proper installation.**

200 SERIES AFco-RAIL LEVEL RAIL

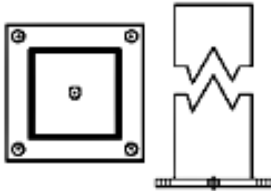
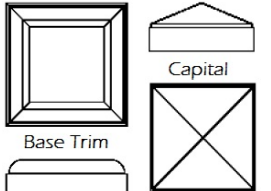
POST INSTALLATION:	
1. Measure and locate the position of the post(s) based on the project layout.	
<p><i>Note: If an over-the-post installation is desired, the post will need to be cut from the standard length to accomplish this. To determine this height, place the post in the desired locations to be installed, and mark for the bracket location as instructed in step 7. Then, mark a line 3/4" above the bracket location marks. This will be the location to cut the post and permit the top rail to be installed flush with the top of the post and allow the deck board to be installed over the top of the post.</i></p> <p>2. Install the post by attaching the aluminum mounting flange to the surface of the deck or balcony. Position the post so the fastener will go into the floor joist, and make sure the decking is firmly attached to the joist at the location of the post. If necessary, use wood blocking as reinforcement underneath the decking where the posts are located. Post mounting fasteners should be able to secure into the joist or reinforcement braces, not just the decking itself. When installing AFCO-Rail Post on top of a wood surface, screws must be lagged into at least 3" of solid wood. Deck boards sized 5/4" or 1 1/2" do not provide sufficient material for a safe installation.</p> <p><i>Note: When installing AFCO-Rail Post onto treated wood surface, install the provided ACQ pad (included in the post kit) between the post base and the treated surface.</i></p>	
3. Position the post to the deck surface. Four 3/8" diameter mounting holes are provided on the mounting flange. Mark the mounting flange hole locations and remove the post. Drill the marked locations into the decking and reinforcement using the proper size drill required for the fasteners being used. Remount the post. Insert the appropriate fasteners to secure the mounting flange to the deck structure.	
4. Finish by sliding the base trim to the bottom of the post to cover the mounting flange.	
5. To install the post cap, set it in place on top of the post and strike with a rubber mallet to drive the post cap onto the post. Silicone or water based caulking may be used to secure the post cap and base trim.	

LEVEL RAIL INSTALLATION:
1. Carefully measure the opening between posts or walls and calculate the length of rail that needs to be cut. Divide the trim length amount in half, and starting with the bottom rail (B), transfer and mark the measurement to each end of the rail. For the sake of baluster spacing or personal preference, all of the trim length could be cut from one end of both rails. Make this determination before cutting the rails. Always refer to local building code requirements to determine the baluster spacing requirements in your area (4" maximum is typical). Carefully cut the rail. Mark top rail (A) and cut. For clearance purposes the top rail is precut 3/4" shorter than the bottom rail.

2. Install support block connectors (G) using self-drilling screws (H) to the underside of bottom rail (B). The support block will be installed in step 10.

Note: One support block, cut from support block material (F), is recommended for rails measuring 72" in length or less; two support blocks for longer lengths. If one support block is required, install the support block connector (G) at center point of bottom rail (B). If two support blocks are required, install support block connectors (G) equal distance from each end of the bottom rail (B).

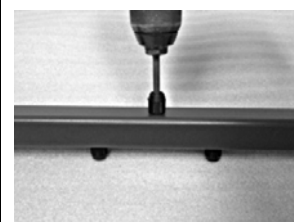

3. To assemble rail, begin with top rail (A) and insert balusters over pre-installed connectors. Firmly tap each baluster with a rubber mallet to ensure the baluster is fully seated against the top rail.

Note: It is recommended to use the box as a pad to prevent scuffing of the painted finish. If installing square balusters, make sure they are properly seated in the slot on the underside of the top rail to prevent twisting.



4. Attach balusters to bottom rail (B) beginning at one end and working to opposite end. Stand the assembly upside down on the surface of the box and firmly tap the bottom rail with a rubber mallet to secure the balusters in place. Stand assembly upright.

Note: Notches are provided on the front of the box to help align balusters and aid in the assembly of the rail in this step.



5. Slide bottom brackets (D) with screw holes down and counter bore holes facing toward the balusters, over each end of the bottom rail (B).



6. The 200 Series deck rail can be installed with or without a deck board on top of the top rail (A). If installing without a deck board on the top rail, measure up 35 1/4" (36" rail height) or 41 1/4" (42" rail height) from the floor and mark a level, horizontal line on the post or wall.

Note: If installing with a deck board on the top rail (A) reduce the above dimensions by the thickness of the deck board being used. Overall rail height may vary by local code or personal preference.

7. Align screw holes in saddle bracket (C) on the horizontal line marked in step 6 making certain the saddle bracket (C) is centered on the post. Mark screw locations. Repeat process at opposite end.



8. Attach both saddle brackets (C) with self-drilling screws (H) at the marked screw locations completed in Step 7. Pre-drilling is recommended.

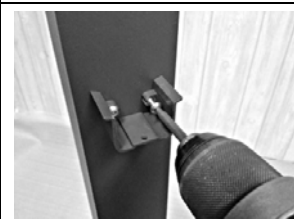

Note: If installing a deck board on the top rail (A), omit this step and do not install the rail caps.

9. Slide the top rail cap (E) on both ends of the top rail (A) and set the rail assembly into the saddle brackets (C) letting the bottom rail hang freely between the posts. Check for level.



10. At the point(s) where you installed support block connectors (step 2), carefully measure the distance from the underside of the bottom rail (B) to the floor. Cut support block material (F) to fit. Remove rail assembly from the saddle brackets (C). Slip support blocks over support block connectors (G). Slide the rail back into place and make certain the rail is plumb.



11. Slide and hold the bottom bracket (D) firmly against the post or wall. Secure the bracket with self-drilling screws (H). Repeat the process on the other side.
Note: Screw holes in the bottom brackets (D) are angled to make mounting the brackets easier.



12. Screw self-drilling screws (H) into the top rail (A) from the underside of each saddle bracket (C) through the provided locating hole to securely fasten the rail.



13. If a deck board is to be installed on top of the rail, carefully measure and cut the material to the length required. Place the deck board on top of the rail and secure from the under-side of the rail as shown, with the appropriate fasteners under the flange of both sides of the rail.



14. If the deck board will not be installed, place the adhesive tab (J) to the top surface of the top rail (A) near the post. Slide the top rail cap (E) towards the post and press down to secure it with the adhesive tab (J).



Note: This photo depicts a fully assembled rail section installed between two posts, with a deck board mounted on the top rail. The left side is butted up to the post and the right side is depicting an application where the post may be cut flush with the top rail for a continuous board to be mounted over the post and provide an uninterrupted sight line.







200 Series AFco-Rail Fixed Stair

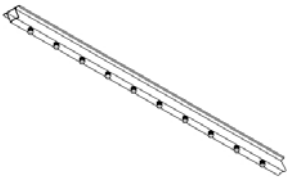
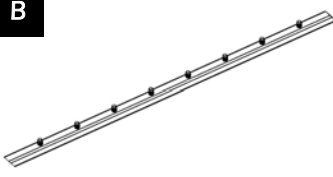
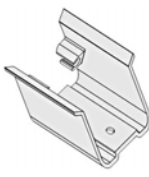
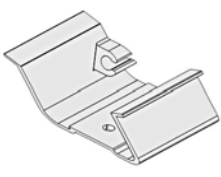
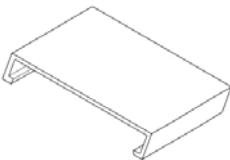
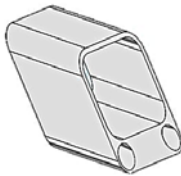
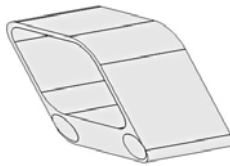

INSTALLATION INSTRUCTIONS

PARTS INCLUDED:

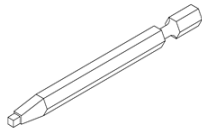
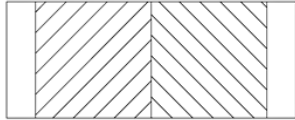
TOP RAIL WITH CONNECTORS (1)	BOTTOM RAIL WITH CONNECTORS (1)	UPPER SADDLE BRACKET (1)	LOWER SADDLE BRACKET (1)
A 	B 	C 	D 
TOP RAIL CAP (2)	UPPER BOTTOM BRACKET (1)	LOWER BOTTOM BRACKET (1)	10" SUPPORT BLOCK (1)
E 	F 	G 	H 
SUPPORT BLOCK CONNECTOR (2)	#10 SELF DRILLING SCREWS	3 1/2 " SQUARE DRIVER BIT (1)	ADHESIVE TAB (1)
I 	J 1" - 4 each 1-1/2" - 8 each 	K 	L 

NOTE: Post and balusters packaged separately.

TOOLS REQUIRED:

Drill bit 5/32" (.156")
 Drill (with adjustable clutch, recommended)
 Hacksaw (with metal cutting blade)
 Level
 Rubber mallet
 Tape measure
 Touch-up paint

FOR A SUCCESSFUL INSTALLATION:

- Read the instructions completely before beginning the installation.
- Plan your railing project. Sketch your project with the actual measurements of your deck or balcony with the location of the posts for the railing that needs to be installed.
- Check local building codes to ensure compliance.
- Check carton(s) to determine part count is complete.
- After cutting rails, balusters, or posts, paint exposed metal for maximum protection against the elements.
- Installation is best accomplished with two people.
- Wear personal protection equipment; safety glasses, etc.
- Use care not to over-torque the screws. Pre-drilling is recommended.
- **Provided hardware to install AFco-Rail is for use with Aluminum AFco-Rail posts. If installing to other surfaces the installer must acquire the appropriate hardware as needed for proper installation.**

200 SERIES AFco-RAIL FIXED STAIR

POSTS INSTALLATION:

1. Begin by determining where the top and bottom post will be located. Mark the desired location of the post.
Note: To ensure post location is compatible with railing, prior to securing to the deck, place both posts in position, and lay the bottom rail along the stair-nosing from top to bottom adjacent to both post. On the rail side of the post, measure up from the top of the rail and ensure there is a minimum of 34" for the 36" rail height and a minimum of 40" for the 42" rail height to the top of the post. Post location may have to be adjusted to ensure minimum is obtained. Repeat this step for the bottom post.

- For railing mounted 36" high use a 44" post at the bottom of the stairs.
- For railing mounted 42" high use a 54" post at the bottom of the stairs.

For a wooden deck position the post so the fasteners will go into the floor joists, and make sure the decking is firmly attached to the joists at the location of the posts. If necessary, use wood blocking as reinforcement underneath the decking where the posts are located. Fasteners which hold the brackets to the surface should be able to secure to joist or reinforcement braces, not just the decking itself.



2. When the final position is determined for the post, mark the hole locations of the four 3/8" diameter mounting holes provided on the base and remove the post assembly. Drill the marked locations into the decking and reinforcement using the proper size drill required for the fasteners being used.



3. Remount the post assembly. Insert the appropriate fasteners then secure the base to the deck structure. Make certain the posts are plumb. If the post requires adjustment, add stainless steel washers under the base plate. Do not install the base post trim and post capitals until step 4 of the rail installation.
Note: When installing AFco- Rail Post onto treated wood surface, install the provided ACO pad that is included in the post kit between the post base and the treated surface.

FIXED RAIL INSTALLATION:

1. Lay the bottom rail (B), with baluster connectors facing up and centered between the posts, on the stair nosing from top to bottom, adjacent to the posts and mark a line on the rail from the inside of each post. Also, make a reference mark on the bracket side of both posts at the point where the top of the rail meets the post.
Note: This reference mark will be used to locate saddle brackets in step 5.



2. Place the top rail (A) next to the bottom rail (B), align the baluster connectors and duplicate the marks from the bottom rail cut line onto the top rail. Now mark the top rail 5/8" shorter on each end; this is the cut line for top rail. Only the top rail is cut 5/8" shorter on each end.



3. Cut the rails along the marked lines.

4. Install the base post trim on the upper and lower posts.

5. The 200 Series deck rail can be installed with or without a deck board installed on the top rail (A).
 If installing without a deck board on the top rail (A), on both the upper and lower post, measure and mark a level line up from the reference marks previously completed in fixed rail instructions step 1 (31" for a 36" rail height or 37" for a 42" rail height).
 If installing with a deck board on the top rail (A) reduce the above dimensions by the thickness of the deck board being used. These measurements may vary by local code or personal preference.

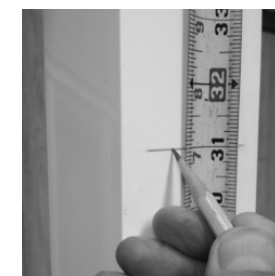

6. Align screw holes in the upper and lower saddle brackets (C&D) on the marked lines. Make sure the brackets are centered on the posts. Mark the screw hole locations with a pencil.



7. Attach saddle brackets (C&D) with 1-1/2" self-drilling screws (J) at the marked screw locations in step 6. Pre-drilling is recommended.

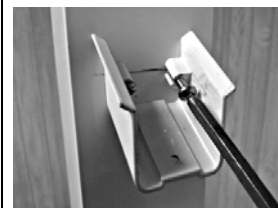

8. Install support block connectors (I) using 1" self-drilling screw (J) to the underside of bottom rail (B). The support block (H) will be installed in step 13.
Note: One support block, cut from support block material (H), is recommended for rails measuring 72" in length or less; two support blocks for longer lengths. If one support block is required, install support block connector (I) at center point of bottom rail (B). If two support blocks are required, install support block connectors (I) equal distance from each end of the bottom rail (B).



9. To assemble rail, begin with top rail (A) and insert balusters over pre-installed connectors. Use a rubber mallet to tap the balusters into place.
Note: It is recommended to use the box as a pad to prevent scuffing of the painted finish. If installing square balusters, make sure they are properly seated in the slot on the underside of the top rail to prevent twisting.



10. Attach balusters to bottom rail (B) beginning at one end and working to the opposite end. Stand the assembly upside down on the surface of the box and tap the bottom rail with a rubber mallet to secure the balusters in place. Stand assembly upright.
Note: Notches are provided on the front of the box to help align balusters and aid in the assembly of the rail in this step.

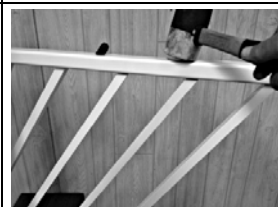

Note: If installing a deck board on the top rail (A), omit this step and do not install the rail cap.

11. Slide the top rail caps (E) over each end of the top rail (A) so the angle of the rail cap matches the angle of the top rail. A small piece of tape may be used to hold the top rail caps (E) in place.

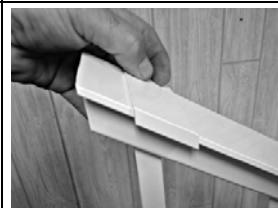

12. Slide bottom brackets (F&G) with the counter bore holes facing down and toward the balusters, over each end of the bottom rail (B) and set the rail assembly into the saddle brackets (C&D) letting the bottom rail hang freely between the post.
Note: May use option to install brackets with holes facing up based on customer preference.



13. At the point(s) where you installed support block connectors (step 8), carefully measure the distance from the underside of the bottom rail (B) to the floor. Cut support block material (H) to fit. Slip support blocks over support block connectors (I). Slide the rail back into place and make certain the rail is plumb.



14. Slide and hold the upper bottom bracket (F) firmly against the top post. Secure the bracket with 1-1/2" self-drilling screws (J). Repeat the process securing lower bottom bracket (G) to the bottom post using 1-1/2" self-drilling screws (J).

Note: Screw holes in brackets (F&G) are angled to make mounting the brackets easier.



Note: If installing a deck board to the top of the rail, omit this step.

15. Apply adhesive tab (L) to flat, top surface of top rail (A), near the post. Slide top rail cap (E) towards the post and press down to secure it with the adhesive tab (L) and press down to secure with the adhesive tab.



16. Screw 1" self-drilling screws (J) into the top rail (A) from the underside of saddle brackets (C&D) through the provided locating hole.



17. If a deck board is to be installed, carefully measure and cut materials to the length and or angle required. Place the deck board on top of the rail and secure from the underside of rail with the appropriate fasteners under the flange of both sides of the rail.



Note: This photo depicts a fully assembled rail section for AFCO 200 Series Fixed Stair installed between two posts on a standard set of stairs without a deck board mounted to the top rail.



300 Series AFCO-Rail Stair Rail









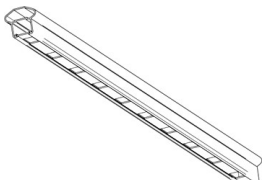
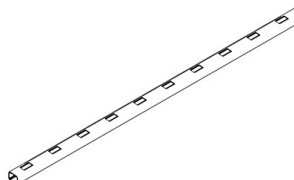

INSTALLATION INSTRUCTIONS

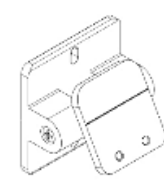
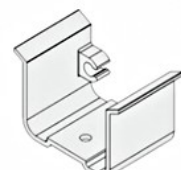

AFCO
Columns and Railings
a Division of AFCO Industries, Inc.

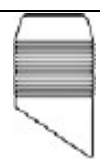
PARTS INCLUDED:

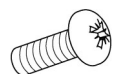
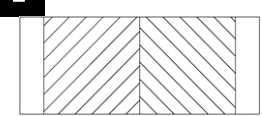
TOP RAIL (1)	BOTTOM RAIL (1)	TOP RAIL HINGE ASSEMBLY (2)	BOTTOM RAIL HINGE ASSEMBLY (2)
A 	B 	C 	D 
SADDLE BRACKETS (2)	SADDLE BRACKET COVER (2)	BOTTOM BRACKET (2)	7" SUPPORT BLOCK (1)
E 	F 	G 	H 
SUPPORT BLOCK CONNECTORS (2)	#10 x 1" SELF DRILLING SCREWS (8 COLOR MATCHED, 4 MILL FINISH)	#10 -24 x 7/16 MACHINE SCREWS (8)	ADHESIVE TAB
I 	J 	K 	L 

300 SERIES AFCO-RAIL ADJUSTABLE RAIL

TOOLS REQUIRED:

Drill bit 5/32" (.156")
T25 Torx Driver (minimum 2") & Bit Holder
Drill (with adjustable clutch, recommended)
Miter Saw (with metal cutting blade)
Level
Rubber Mallet
Tape Measure
Touch-up paint

NOTES:

- Post and balusters packaged separately.

FOR A SUCCESSFUL INSTALLATION:

- Read the instructions completely before beginning the installation.
- Plan your railing project. Sketch your project with the actual measurements of your deck or balcony complete with post locations.
- Check local building codes to ensure compliance.
- Check carton(s) to determine part count is complete.
- After cutting rails, balusters, or posts, paint exposed metal for maximum protection against the elements.
- Installation is best accomplished with two people.
- Wear personal protection equipment, safety glasses, etc.
- Use care not to over-torque the screws. Pre-drilling is recommended.
- **Provided hardware to install AFCO-Rail is for use with Aluminum AFCO-Rail posts. If installing to other surfaces the installer must acquire the appropriate hardware as needed for proper installation.**

POSTS INSTALLATION:

1. Determine the location and position of the upper and lower post based on the project layout. Mark the desired location of the posts.
To ensure post location is compatible with railing prior to securing to the deck surface, place both posts in position, and lay the bottom rail along the stair from top to bottom adjacent to both posts (see photo). On the rail side of the post, measure up from the top of the rail and ensure there is a minimum of 35-1/2" for the 36" rail height and a minimum of 41-1/2" for the 42" rail height to the top of the post. Post location may have to be adjusted to ensure minimum is obtained. Repeat this step for the bottom post.

- For railing mounted 36" high use a 44" post at the bottom of the stairs.
- For railing mounted 42" high use a 54" post at the bottom of the stairs.

For a wooden deck position the post so the fasteners will go into the floor joists, and make sure the decking is firmly attached to the joists at the location of the posts. If necessary, use wood blocking as reinforcement underneath the decking where the posts are located.

Fasteners which hold the brackets to the surface should be able to secure to joist or reinforcement braces, into at least 3" of solid wood.



2. When the final position is determined for the post, mark the hole locations of the four 3/8" diameter mounting holes provided on the base and remove the post assembly. Drill the marked locations into the decking and reinforcement using the proper size drill required for the fasteners being used.

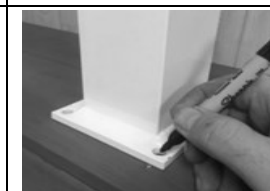

3. Remount the post assembly. Insert the appropriate fasteners then secure the base to the deck structure. Make certain the posts are plumb. If the post requires adjustment, add stainless steel washers under the base plate. Do not re-install the base post trim until step 2 of the rail installation.

Note: When installing AFco- Rail Post onto treated wood surface, install the provided ACQ pad that is included in the post kit between the post base and the treated surface.

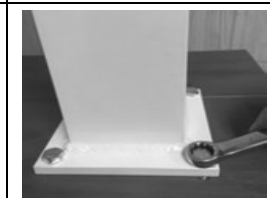

STAIR RAIL INSTALLATION:

1. Lay the Bottom Rail (B) on the stair from top to bottom and adjacent to the posts previously installed. Make a level reference mark with a pencil on the bracket side of both the upper and lower posts at the point where the top of the rail meets the post.
Note: Illustration photo shown is the upper post.



2. Install the base post trim on both the upper and lower posts.

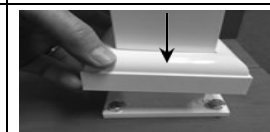

3. Locate the Bottom Rail Hinge Assembly (D) first by measuring up from the reference marks placed on the posts in step 1 based on the chart below and place mark at those locations on the bracket side of the post for the Bottom Hinge Assembly only. This will be the centerline mounting point for the bottom hinge assemblies. (Note: Centerline mark must be a minimum of 2-5/8" from the deck surface to allow space for the base trim to be installed.) From the centerline marks of the Bottom Rail Hinge Assemblies measure up the distance indicated on the chart to locate the centerline of the Top Rail Hinge Assemblies.

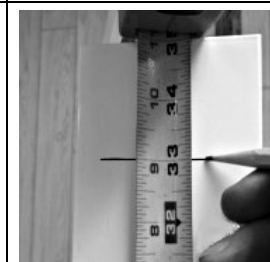

UPPER POST

LOWER POST

	Bottom Rail Hinge	Top Rail Hinge	Bottom Rail Hinge	Top Rail Hinge
36" Rail	Up 1/2"	33"	Up 1-1/2"	33"
42" Rail	Up 1/2"	39"	Up 1-1/2"	39"

4. To locate the mounting hole locations of Top Rail Hinge Assembly (C) and the Bottom Rail Hinge Assembly (D) place a mark 1" above and below each of the level line marks centered on the posts from step 3 (see photo) This will be the location of the fasteners to attach the Hinge Assemblies to the post.

Note: Pre-drilling is recommended at these locations for the fasteners.

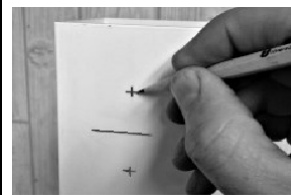

5. Using the Color Matched #10-1" Self-Drilling Screws (J) secure the Top Rail Hinge Assembly (C) and the Bottom Rail Hinge Assembly (D) to the upper and lower posts through the marked and/or pre-drilled hole locations. (Mounting holes are elongated to allow a small amount of adjustment if necessary to properly align the hinge assemble with the rail.)

Note: Two screws are required to mount each bracket to properly secure in place. Depending on the post location, it may be necessary to temporarily remove the post or disassemble the hinge for adequate access to install the fasteners.



6. Attach the Saddle Brackets (E) to the Top Rail Hinge Assembly (C) using the #10-24 x 7/16" Machine Screws (K).

Note: Two screws are required to mount each bracket to properly secure in place.

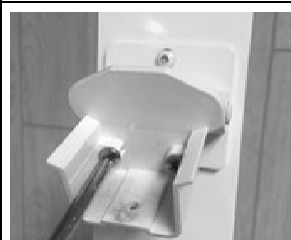

7. On a flat surface (use the box as a pad to protect painted surfaces), Align the holes of both the Top Rail (A) and the Bottom Rail (B). Place a mark at the determined midpoint of the Bottom Rail (B) (Either baluster on center, or the space between the baluster centered as shown) Transfer that mark to the Top Rail (A).

Note: There must be at least 2" between the cut ends and the center of the first baluster holes for proper clearance of the mounting brackets. Depending on the installation, for best spacing of the first baluster on each end, it may be necessary to shift the center point of the rail from a baluster to a space between two balusters or vice versa.

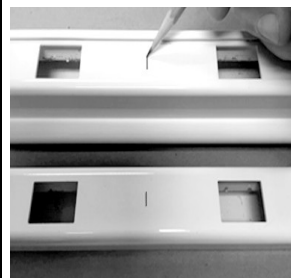

8. From the centerlines marked on both the Top Rail and Bottom Rail in step 7, place a mark 1/2" to the left of the centerline on the Top Rail (A) and 3/8" to the right of the centerline on the Bottom Rail (B). These marked locations will become the new centerline mark of both rails to determine cutting locations.

NOTE: When viewed as the photo shown, the right side of both the Top Rail and Bottom Rail will be installed to the lower side of the stair.

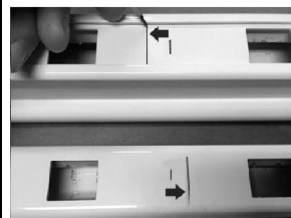

9. To determine rail length measure the distance between the parallel faces of the Bottom Rail hinge assembly brackets installed in step 5. From the new determined centerlines of Top Rail (A), and Bottom Rail (B) completed in steps 7 & 8, measure half the distance of the determined bottom rail length, and place a mark both right and left of the centerlines. This will be the cut marks for the Bottom Rail (B) only. Shorten the Top Rail (A) by an additional 3/8" from each mark previously placed at the ends of the rail to accommodate bracket clearance. This will be the cut marks for the Top Rail (A).

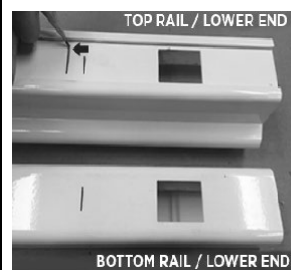

10. Install Support Block Connectors (I) using Mill Finish #10-1" Self-Drilling Screw (J) to the underside of Bottom Rail (B).

Note: One Support Block, cut from Support Block material (H), is recommended for rails measuring 72" in length or less; use two Support Blocks for longer lengths. If one Support Block is required, install Support Block Connector (I) at center point of bottom rail (B). If two Support Blocks are required, install Support Block Connector (I) equal distance from each end of the Bottom Rail (B).



11. To assemble rail, begin with Top Rail (A) and insert balusters into each baluster hole. Use a rubber mallet to tap the balusters into place until fully seated into the Top Rail.

Note: It is recommended to use the box as a pad to prevent scuffing of the painted finish.

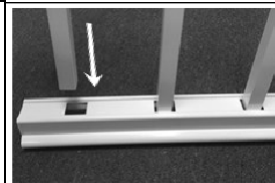

12. Insert balusters in the Bottom Rail (B) the same as in step 1, beginning at one end and working to the opposite end. Stand the assembly upside down on the surface of the box and tap the Bottom Rail (B) with a rubber mallet to secure the balusters in place. Stand assembly upright.

Note: Notches are provided on the front of the box to help align balusters and aid in the assembly of the rail in this step.

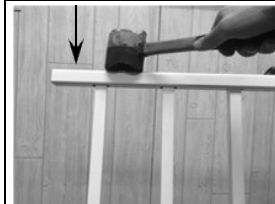

13. Slide Saddle Bracket Covers (F) over each end of the Top Rail (A) at least 3-4" inward over each end of the rail. Covers will be secured in final position later.

Note: A small piece of tape may be required to hold the bracket covers in place.



14. Slide Bottom Brackets (G) with the counter bore holes facing down and toward the balusters, over each end of the Bottom Rail (B). A small piece of tape may be required to hold lower bottom brackets in place. Next, set the rail assembly into the Saddle Brackets (E) previously installed (step 6) letting the Bottom Rail (B) hang freely between the posts.



15. At the point(s) where you installed Support Block Connector(s) (step 11), carefully measure the distance from the underside of the bottom rail (B) to the floor or step. Cut support block material (H) to fit. Slip the Support Block(s) over Support Block Connector (s) (I). Slide the rail back into place and make certain the rail is plumb.



16. Slide and hold the Bottom Brackets (G) against the Bottom Rail Hinge Assembly (D) attached to the upper and lower post and secure with the #10-24 x 7/16 Phillips Screws (K).

Note: Two screws are required to mount each bracket to properly secure in place.



17. Apply Adhesive Tab (L) to flat, top surface of the Top Rail (A), near the post. Slide Bracket Covers (F) to interlock with flange on the Saddle Brackets (E).



18. Screw Mill Finish #10-1" Self-Drilling Screws (J) into the Top Rail (A) from the underside of Saddle Brackets (E) through the provided locating hole to securely fasten the rail in place.









300 Series AFco-Rail Stair Rail

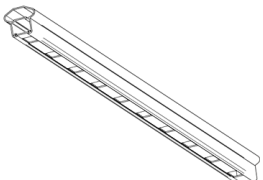
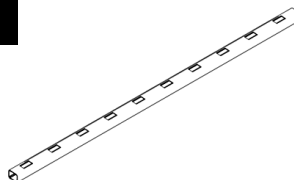

INSTALLATION INSTRUCTIONS

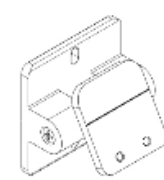
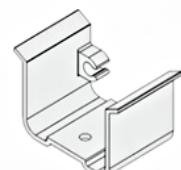
300 SERIES AFco-RAIL ADJUSTABLE RAIL

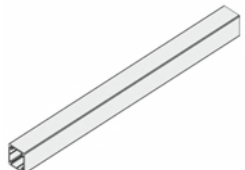
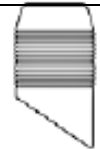
PARTS INCLUDED:

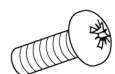
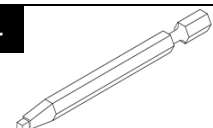
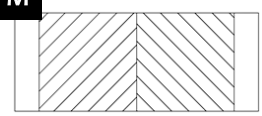
TOP RAIL (1)		BOTTOM RAIL (1)		TOP RAIL HINGE ASSEMBLY (2)		BOTTOM RAIL HINGE ASSEMBLY (2)	
A		B		C		D	
SADDLE BRACKETS (2)		SADDLE BRACKET COVER (2)		BOTTOM BRACKET (2)		10" SUPPORT BLOCK (1)	
E		F		G		H	
SUPPORT BLOCK CONNECTORS (2)		#10 x 1" SELF DRILLING SCREWS (8 COLOR MATCHED, 4 MILL FINISH)		#10 -24 x 7/16 PHILLIPS SCREWS (8)		3 1/2" SQUARE DRIVER BIT	
I		J		K		L	
						ADHESIVE TAB	
							

TOOLS REQUIRED:

Drill bit 5/32" (.156")
 Drill (with adjustable clutch, recommended)
 Miter Saw (with metal cutting blade)
 Level
 Phillips Screw Driver
 Rubber mallet
 Tape measure
 Touch-up paint

NOTES:

- Post and balusters packaged separately.

FOR A SUCCESSFUL INSTALLATION:

- Read the instructions completely before beginning the installation.
- Plan your railing project. Sketch your project with the actual measurements of your deck or balcony complete with post locations.
- Check local building codes to ensure compliance.
- Check carton(s) to determine part count is complete.
- After cutting rails, balusters, or posts, paint exposed metal for maximum protection against the elements.
- Installation is best accomplished with two people.
- Wear personal protection equipment; safety glasses, etc.
- Use care not to over-torque the screws. Pre-drilling is recommended.
- **Provided hardware to install AFco-Rail is for use with Aluminum AFco-Rail posts. If installing to other surfaces the installer must acquire the appropriate hardware as needed for proper installation.**

POSTS INSTALLATION:

1. Determine the location and position of the upper and lower post based on the project layout. Mark the desired location of the posts.
 To ensure post location is compatible with railing prior to securing to the deck surface, place both posts in position, and lay the bottom rail along the stair from top to bottom adjacent to both post (see photo) . On the rail side of the post, measure up from the top of the rail and ensure there is a minimum of 34-1/2" for the 36" rail height and a minimum of 40-1/2" for the 42" rail height to the top of the post. Post location may have to be adjusted to ensure minimum is obtained. Repeat this step for the bottom post.

- **For railing mounted 36" high use a 44" post at the bottom of the stairs.**
- **For railing mounted 42" high use a 54" post at the bottom of the stairs.**

For a wooden deck position the post so the fasteners will go into the floor joists, and make sure the decking is firmly attached to the joists at the location of the posts. If necessary, use wood blocking as reinforcement underneath the decking where the posts are located.
 Fasteners which hold the brackets to the surface should be able to secure to joist or reinforcement braces, into at least 3" of solid wood.

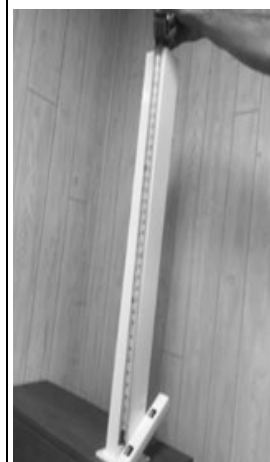

2. When the final position is determined for the post, mark the hole locations of the four 3/8" diameter mounting holes provided on the base and remove the post assembly. Drill the marked locations into the decking and reinforcement using the proper size drill required for the fasteners being used.



3. Remount the post assembly. Insert the appropriate fasteners then secure the base to the deck structure. Make certain the posts are plumb. If the post requires adjustment, add stainless steel washers under the base plate. Do not re-install the base post trim until step 2 of the rail installation.
Note: When installing AFCO- Rail Post onto treated wood surface, install the provided ACQ pad that is included in the post kit between the post base and the treated surface.



STAIR RAIL INSTALLATION:

1. Lay the Bottom Rail (B) on the stair from top to bottom and adjacent to the posts previously installed. Make a level reference mark with a pencil on the bracket side of both the upper and lower posts at the point where the top of the rail meets the post.
Note: Illustration photo shown is the upper post.



2. Install the base post trim on both the upper and lower posts.

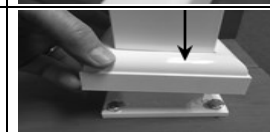

3. To mark the Top Rail Hinge Assembly (C) and the Bottom Rail Hinge Assembly (D) locations on the posts, measure up from the reference marks in Step 1 and mark the bracket side of the posts per the table below.

Note: Illustration photo shown is the upper post.

	Upper Post		Lower Post	
	Bottom Rail Hinge	Top Rail Hinge	Bottom Rail Hinge	Top Rail Hinge
36" Rail	1/2"	33"	1-1/2"	34"
42" Rail	1/2"	39"	1-1/2"	40"

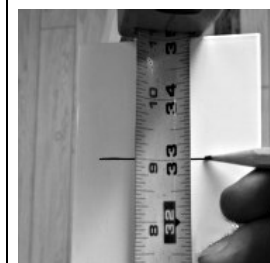

4. To locate the mounting hole locations of Top Rail Hinge Assembly (C) and the Bottom Rail Hinge Assembly (D) place a mark 1" above and below each of the level line marks centered on the posts from step 3 (see photo) This will be the location of the fasteners to attach the Hinge Assemblies to the post.

Note: Pre-drilling is recommended at these locations for the fasteners.

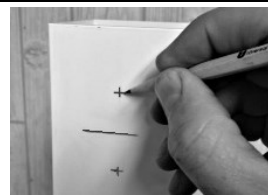

5. Using the Color Matched #10-1" Self Drilling Screws (J) secure the Top Rail Hinge Assembly (C) and the Bottom Rail Hinge Assembly (D) to the upper and lower posts through the marked and/or pre-drilled hole locations. (Mounting holes are elongated to allow a small amount of adjustment if necessary to properly align the hinge assemble with the rail.)

Note: Two screws are required to mount each bracket to properly secure in place.

Depending on the post location, it may be necessary to temporarily remove the post or disassemble the hinge for adequate access to install the fasteners.



6. Attach the Saddle Brackets (E) to the Top Rail Hinge Assembly (C) using the #10-24 x 7/16" Phillips Screws (K).

Note: Two screws are required to mount each bracket to properly secure in place.



7. Align the Bottom Rail Hinge Assemblies (D) so they are facing parallel to each other, and measure the distance between upper and lower Bottom Rail Hinge Assemblies (D) previously mounted on the posts in step 5.



8. On a flat surface, (use the box as a pad to prevent scuffing of painted surfaces), lay the Top Rail (A) and Bottom Rail (B) side by side with baluster holes facing upward and aligned. Transfer the measurement in step 7 to the Bottom Rail (B). Ensure the baluster holes are centered between the cut locations.

Note: There must be at least 2" between the cut ends and the center of the first baluster holes for proper clearance of the mounting brackets. Depending on the installation, for best spacing of the first baluster on each end, it may be necessary to shift the center point of the rail from a baluster to a space between two balusters or vice versa.

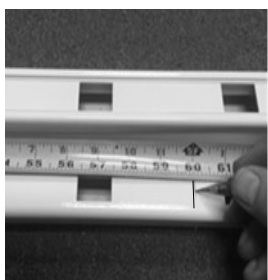

9. Now mark the Top Rail (A) 3/8" shorter on each end than the Bottom Rail (B) was marked also ensuring the baluster holes are centered. Cut to length the Top Rail (A) and Bottom Rail (B) along the marked lines.

Note: There must be at least 2" between the cut ends and the center of the first baluster holes for proper clearance of the mounting brackets. Depending on the installation, for best spacing of the first baluster on each end, it may be necessary to shift the center point of the rail from a baluster to a space between two balusters or vice versa.

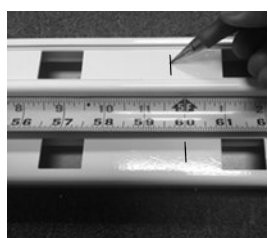

10. Install Support Block Connectors (I) using Mill Finish #10-1" Self Drilling Screw (J) to the underside of Bottom Rail (B).

Note: One Support Block, cut from Support Block material (H), is recommended for rails measuring 72" in length or less; use two Support Blocks for longer lengths. If one Support Block is required, install Support Block Connector (I) at center point of bottom rail (B). If two Support Blocks are required, install Support Block Connector (I) equal distance from each end of the Bottom Rail (B).



11. To assemble rail, begin with Top Rail (A) and insert balusters into each baluster hole. Use a rubber mallet to tap the balusters into place until fully seated into the Top Rail.

Note: It is recommended to use the box as a pad to prevent scuffing of the painted finish.

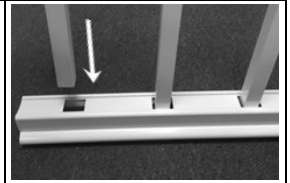

12. Insert balusters in the Bottom Rail (B) the same as in step 1, beginning at one end and working to the opposite end. Stand the assembly upside down on the surface of the box and tap the Bottom Rail (B) with a rubber mallet to secure the balusters in place. Stand assembly upright.

Note: Notches are provided on the front of the box to help align balusters and aid in the assembly of the rail in this step.

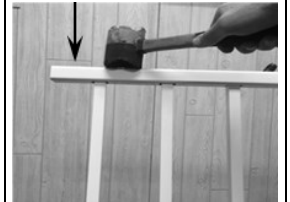

13. Slide Saddle Bracket Covers (F) over each end of the Top Rail (A) at least 3-4" inward over each end of the rail. Covers will be secured in final position later.

Note: A small piece of tape may be required to hold the bracket covers in place.



14. Slide Bottom Brackets (G) with the counter bore holes facing down and toward the balusters, over each end of the Bottom Rail (B). A small piece of tape may be required to hold lower bottom brackets in place. Next, set the rail assembly into the Saddle Brackets (E) previously installed (step 6) letting the Bottom Rail (B) hang freely between the posts.



15. At the point(s) where you installed Support Block Connector(s) (step 11), carefully measure the distance from the underside of the bottom rail (B) to the floor or step. Cut support block material (H) to fit. Slip the Support Block(s) over Support Block Connector(s) (I). Slide the rail back into place and make certain the rail is plumb.



16. Slide and hold the Bottom Brackets (G) against the Bottom Rail Hinge Assembly (D) attached to the upper and lower post and secure with the #10-24 x 7/16 Phillips Screws (K).

Note: Two screws are required to mount each bracket to properly secure in place.



17. Apply Adhesive Tab (M) to flat, top surface of the Top Rail (A), near the post. Slide Bracket Covers (F) to interlock with flange on the Saddle Brackets (E).



18. Screw Mill Finish #10-1" Self Drilling Screws (J) into the Top Rail (A) from the underside of Saddle Brackets (E) through the provided locating hole to securely fasten the rail in place.



AFCO-Rail QuickTrac Level



INSTALLATION INSTRUCTIONS

TOOLS NEEDED:

#2 Square Drive Bit Tip
 Drill (with adjustable clutch recommended)
 Hacksaw (with metal cutting blade)

Miter Saw
 Rubber Mallet
 Tape Measure

1. Cut the top and bottom wood rails as required for the installation. Place the bottom QuickTrac (with two recessed grooves) on the bottom wood rail, and center the first hole of either end of the QuickTrac with one end of the bottom wood rail. The layout will now be completed on the opposite end of the rail.

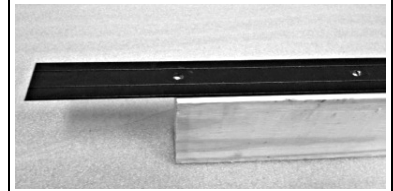

2. From the layout end of the bottom wood rail, mark the center of the hole closest to but does not exceed 8 inches. Divide this measurement by 2.

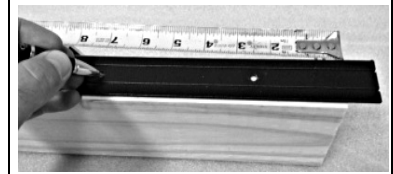

3. From the same end of the wood rail place a mark of that determined dimension on the wood rail. This mark is the location where the first baluster connector will be installed to the wood rail through the QuickTrac .

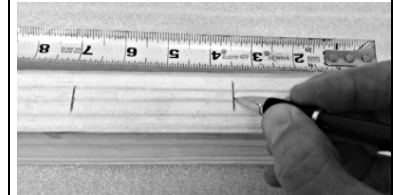

4. Place the top wood rail parallel to bottom rail with ends flush, and transcribe the same mark to the top wood rail.

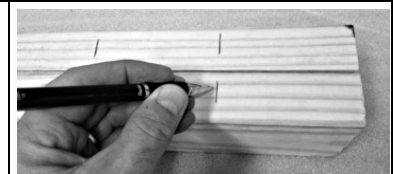

5. Fasten the QuickTrac on the top and bottom wood rails through each pre-drilled hole using the required baluster connectors and screws, starting at the first hole marked locations. Cut the excess aluminum strip material from the ends flush with the wood rail.

Note: Top QuickTrac has two raised ribs that will be installed towards the balusters, the Bottom QuickTrac has two grooves that will be installed towards the balusters to prevent square balusters from turning.

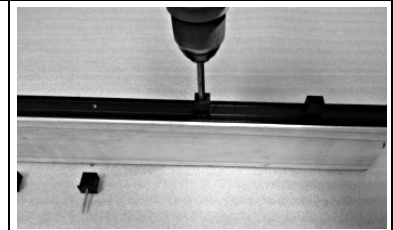

6. Place balusters over installed connectors on the bottom rail and tap down with a rubber mallet until all balusters are fully seated in place. Attach the top rail to the balusters starting at one end and working towards the opposite end tapping with a rubber mallet to fully seat each baluster over the connectors.



Position and install rail section in the location required using the appropriate fasteners your project layout requires and or according to local building codes.
Note: For railings longer than four (4') feet, permanent support blocks between the bottom rail and the deck are strongly recommended.



AFCO-Rail QuickTrac Stair



INSTALLATION INSTRUCTIONS

TOOLS NEEDED:

#2 Square Drive Bit Tip
Drill (with adjustable clutch recommended)
Hacksaw (with metal cutting blade)

Miter Saw
Rubber Mallet
Tape Measure

1. Cut the top and bottom wood rails as required for the installation. Place the bottom wood rail on a level work surface with the angle cut pointing down, and towards the right. Place the bottom QuickTrac (with two recessed grooves) on the wood rail and center the first hole of either end of the QuickTrac with the left end of the bottom wood rail. The layout will now be completed on the opposite end of the rail.

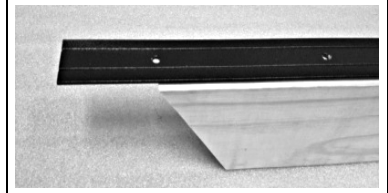

2. From the layout end of the wood rail, mark the center of the hole closest to but does not exceed 8 inches. Divide this measurement by 2.

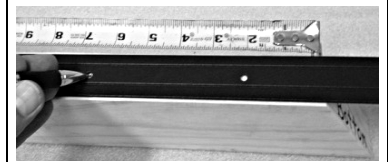

3. From the same end of the wood rail, place a mark of that determined dimension on the wood rail. This mark is the location where the first baluster connector will be installed to the wood rail through the QuickTrac .

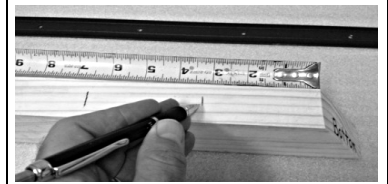

4. To transpose the dimensions to the top wood rail, place the top rail so that the angle cut is facing the opposite direction as the bottom rail. Position the right end of the top rail so the point of the end cut meets parallel to the start of the bottom rail angle. Transfer the mark from the bottom rail previously completed in step 2 to the top rail.

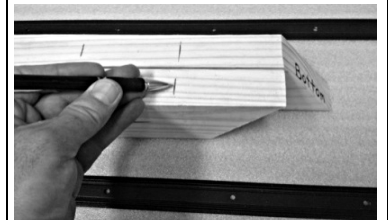

5. Fasten QuickTrac on the top and bottom wood rails through each pre-drilled hole using the required baluster connectors and screws, starting at the first hole marked locations. Connectors are installed in the same direction as the rail cut angles. Once all baluster connectors are installed cut the excess aluminum strip material from the ends flush with the wood rail.

Note: Top QuickTrac has raised ribs that will be installed towards the balusters to prevent square balusters from turning.



6. Place balusters over installed connectors on the bottom rail and tap down with a rubber mallet until all balusters are fully seated in place. Attach the top rail to the balusters starting at one end and working towards the opposite end tapping with a rubber mallet to fully seat each baluster over the connectors.



Position and install rail section in the location required using the appropriate fasteners your project layout requires and or according to local building codes.
Note: For railings longer than four (4') feet, permanent support blocks between the bottom rail and the deck are strongly recommended.



AFCO-Rail Welded Gate



INSTALLATION INSTRUCTIONS

TOOLS & ITEMS NEEDED:

Drill (with appropriate tools to predrill holes and or install hardware)
Hand tools (to install required hardware)
Hinges, Latches, and Gate locks (sold separately)
Level
Tape Measure

1. Place the gate in the opening where it is to be installed. Adjust the height as needed with blocks or shims for the preferred installation position and or location that matches the height of the railing that will also be installed.

Note: Drain or "weep" holes in the frame of the gate must be down when installed.

2. Once the gate position is determined, mark the locations where the hardware (hinges and gate latches) will be installed on the post or determine another other appropriate mounting location.

3. Install the hinges and other hardware (locks, latches) with the appropriate hardware to the post or other suitable mounting location, to properly support the gate.

4. Once all hardware is installed, ensure all mechanisms (hinges, latches, and locks) operate as required.

AFCO-RAIL WELDED GATE

Note: Illustration photos below are a welded gate assembly with hinges installed on the left, a latch installed the on the right, between two posts.



AFCO-Rail Adjustable Gate



INSTALLATION INSTRUCTIONS

TOOLS & ITEMS NEEDED:

Drill (with appropriate tools to predrill holes and or install hardware)
 Hand tools (to install required hardware, screw drivers, wrenches etc.)
 Hinges, Latches, and Gate locks (not provided, but sold separately)
 Level
 Miter Saw (with metal cutting blade)
 Tape Measure

1. Measure the width of the opening where the gate is to be installed. Subtract 5-1/4" from this overall dimension to determine the cut length for the top and bottom rails. The cut lengths of the top and bottom rails determined in this step are based on using hardware, hinges, latches etc., purchased from AFCO.
Note: An Adjustable Gate Kit and a Level Rail Kit is required for the gate assembly.

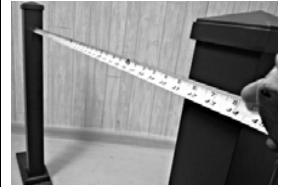

2. Place the top and bottom rail on a level surface, align baluster connectors and determine where the center of the gate will be. (Baluster on center or space on center). After determining the centerline, measure from that point, half the distance calculated in step 1 towards each end of the top and bottom rail and place a mark.
Note: A minimum of 1 5/8" is required from the rail ends to the center of the first balusters on each end to allow for bracket clearance. Baluster connectors may require removal to properly install brackets.

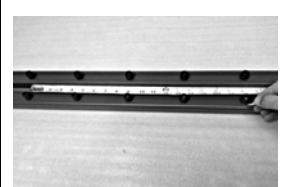

3. Start assembling gate by inserting balusters over the baluster connectors on the top rail. With the top rail on a protective surface, firmly tap each baluster with a rubber mallet to ensure the balusters are fully seated.



4. Attach balusters to bottom rail starting at one end and working to the opposite end. Stand unit upside down and firmly tap the bottom rail with a rubber mallet to secure the balusters in place.



5. Locate bottom brackets in the Adjustable Gate Kit and slide each one onto the ends of the bottom rail with the counter bore holes up and facing toward the balusters.



6. Locate the two side post assemblies from the Adjustable Gate Kit and insert each post assembly onto the top rail of the gate assembly allowing the bottom rail to hang freely.



7. With the gate assembly hanging between the posts, place a mark on each of the posts at the point where the lowest part of the bottom bracket ends. Now remove the posts from the gate assembly and cut at the marked locations.



AFCO-RAIL ADJUSTABLE GATE

8. Re-install the posts cut to the correct length to the gate assembly and position the bottom brackets centered against the posts. Secure each bottom bracket to the post with 2 each of the provided # 10 x 1" non-painted self-drilling screws.



9. Ensure the bottom rail is fully inserted into the installed bottom bracket against post, and install 1 each of the #8 x 3/4" painted head screws through the underside of the bottom brackets also piercing through the rail to secure in place (Pre-drilling is recommended).



10. Position the top of the post assembly over the top rail so that the baluster is parallel to the post and install 1 each of the #8 x 3/4" painted head screw to the underside of the top post brackets through the locating hole, piercing into, and securing the top rail in place.



11. Now install the flat strap braces by placing the gate assembly on a flat work surface. Remove the side mounted screws from both of the post caps on the same side which hold the post caps in place. Place the hole on one end of each strap over the hole of the removed screw in an "X" pattern to the opposite bottom corners of the gate assembly. Mark, cut and pre-drill holes in the braces (if required), so the brace attaches at the bottom of each opposite side post (as shown in the below assembly photo of step 13). Re-install the screws through the braces and post caps and install a screw in the "X" brace at the bottom of the post using the provided #8 x 3/4" painted head screws.

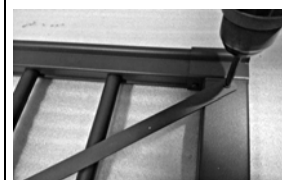
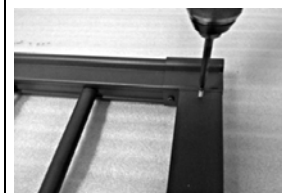

12. Install 1 ea. of the #8x3/4" painted head screws through both "X" braces and into the baluster with the provided stainless washer placed between the braces and the baluster. (Pre-drilling is recommended) If "X" braces do not cross at a baluster use two screws going through each of the balusters and the brace.



13. Place gate into position as required and install necessary hardware (hinges, latch, locks etc.) and ensure all mechanisms operate as required.
 Note: Illustration is an adjustable gate assembly with hinges installed on the left, a latch installed on the right, between two posts.



6" Square Newel Post (Fluted & Smooth)

INSTALLATION INSTRUCTIONS

Note: The following instructions are for the 6" Newel Post using the AFCO Hurricane Bracket System.

1. To assemble the post, snap the interlocks of two staves together beginning at one end and continuing along the length of the post. Continue to add post staves in this manner until all staves are together. Tap lightly with a rubber mallet if necessary to ensure the joints are fully engaged.

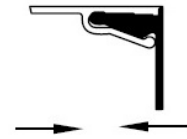

2. With the post on a protective surface lay the post on its side. Place the outside plate of the hurricane bracket kit flush with the end of the column with the splines towards the post and clamp to the post shaft to prevent movement. Drill a 1/4" dia. hole in the post stave using the holes in the outside plate as a guide. Position the inside plate and assemble with bolts and washers provided. Make certain the nuts and washers are to the inside of the column and tighten with a wrench. Repeat this process on the other three staves of the post also at the bottom of the post.

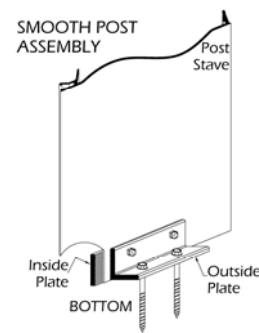
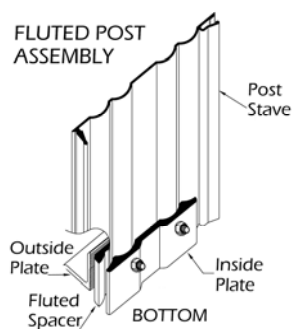

3. Place the post upright in the location to be installed. Mark the hole locations through the outside plate mounting holes on the floor surface.

4. Remove the post from the marked location and using a 3/16" diameter bit pre-drill the holes at the marked locations.

Note: If drilling in concrete the hole depth must be at least 1/4" deeper than the blue Tapcon screws and make certain the hole is free of dust and debris.

If mounting onto wood decking position the post so the fasteners will go into the floor joists, and make sure the decking is firmly attached to the joists at the location of the posts. Screws must be lagged into at least 3" of solid wood. If necessary, add additional material to the underside of the surface for proper support.

5. Reposition the post at the pre-drilled hole locations and use suitable fasteners to attach post to floor of decking. Do not over torque screws. (Check with distributor for additional fasteners if needed)

6. Carefully slide base over the top of the post to the bottom of the post so it is flush with the floor.

7. Place the capital into position on top of the post and secure with and secure with provided fasteners.

Note: The following instructions are for the 6" Newel Post over an existing post such as a 4 x 4 wood post.

1. Complete Step (1) above to assemble the Newel Post.

2. Place assembled Newel Post over existing post and fasten using appropriate methods and fasteners according to standard construction practices.

3. Carefully slide base over the top of the post to the bottom of the post so it is flush with the floor. Silicone or water based caulk may be used to secure the base in place.

4. Place the capital into position on top of the post and secure with provided fasteners.

ADA Rail Connector



INSTALLATION INSTRUCTIONS

TOOLS NEEDED:

#2 Square Driver Tip
Drill
Miter Saw with a metal cutting blade*
(or Hacksaw with a metal cutting blade)

Pliers
Rubber Mallet
Tape Measure

*preferred method of cutting

1. Mark the centerline of the rail connector. Lightly squeeze the connector with pliers and insert into the end of the painted ADA rail until inserted to the marked centerline.

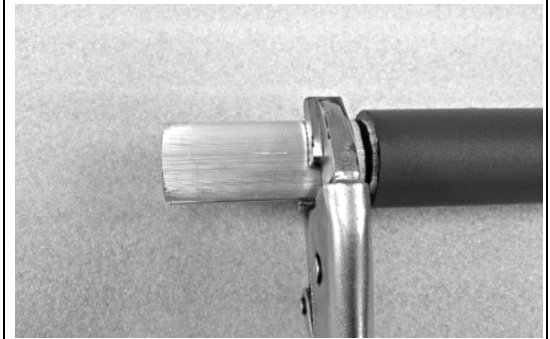

2. Use the provided fasteners and install one of the screws so it pierces through both the rail and connector. Pre-drilling is recommended. (This secures the connector in place to prevent from sliding when installing the next joining piece of ADA rail). Install screws on what will be the underside of the installed rail so they will not be visible. Screw heads can be painted with touch up paint to further conceal them.



3. Measure and cut, if required, the next piece of ADA rail to be installed. Install the next piece of the rail over the remaining exposed end of the connector until the two pieces of ADA rail meet, and there is no gap between the ends of the rails. A rubber mallet may be needed to tap parts in place.

Note: Ensure cuts are made square to minimize any visible joints. Cut ends may also be painted to reduce the effect of any visible joint.

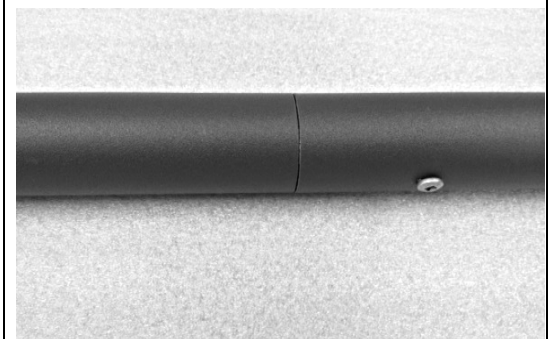

4. Use the provided fasteners and install a screw into the rail the same as in step 2, so that it will pierce through both the rail and the connector. The installation is now complete for this connection and more components can be installed as required.

