

Through-the-Post Mount

Straight Cable Runs up to 25 feet

Deck 1 has dedicated end posts for each run, and the posts are situated such that the back side of the posts are all accessible, meaning you can use a *through-the-post* configuration for all runs. This is both the most economical solution and where the fittings are least visible.

For 1-1/2" metal square tube, use the 212 Series.

For 2" square tube, use the 232 Series.

For 2-3/8" square tube, use the 224 Series.

The tensioning device is, respectively, a 1 1/2", 2", or 2-3/8" long Invisiware® Receiver, which installs flush-through the tube on one end. A same-length Pull-Lock® fitting is installed flush-through the other end.

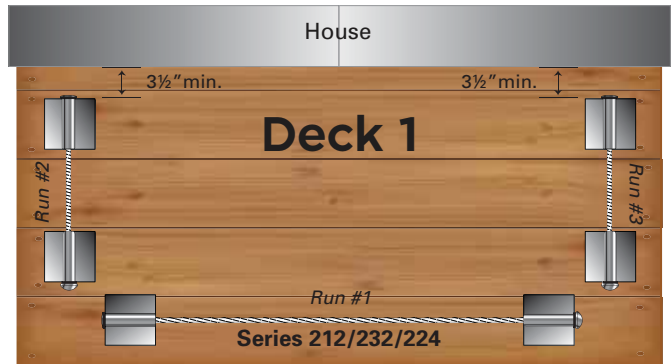

Tools needed for 212, 232, and 224 Series:

5/32 drill bit if 1/8" cable, 7/32 if 3/16"

29/64 drill bit for Receiver and Pull-Lock® installation

3/16 hex wrench for tensioning Receiver

Cable cutting tool

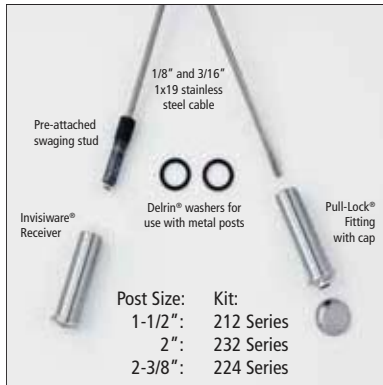

Series 212, 232, and 224 Kits

Cable Length	1/8" cable			3/16" cable		
	1 1/2" metal post	2" metal post	2-3/8" metal post	1 1/2" metal post	2" metal post	2-3/8" metal post
	PART NO.	PART NO.	PART NO.	PART NO.	PART NO.	PART NO.
5'	21205	23205	22405	21205-6	23205-6	22405-6
10'	21210	23210	22410	21210-6	23210-6	22410-6
15'	21215	23215	22415	21215-6	23215-6	22415-6
20'	21220	23220	22420	21220-6	23220-6	22420-6
25'	21225	23225	22425	21225-6	23225-6	22425-6

Through-the-Post Mount

Straight Cable Runs over 25 feet and Cable Runs through Corners

Longer cable runs need more take-up in the tensioning device, so the 224 Series stands in for the 212 and 232 for long runs and cable runs through one corner.

When taking cable railing through a corner, do not bend the cable past 45° at any one time. If turning 90°, a 2-step turn using a double corner post configuration is required, as in Deck 1.

Use the 224 Series.

The tensioning device is a 2-3/8" long Invisiware® Receiver, which installs through the metal post on one end. A Pull-Lock® fitting of the same length is installed through the other end.



When going around two corners, it's necessary to tension the cable from both ends as shown in Deck 2.

Use the 272 Series.

The tensioning devices are a 3 1/2" long Invisiware® Receiver, which installs through the post on one end, and a Push-Lock® Stud on the other end, which is threaded into a 2.3" long Receiver.



Since the 272 Series is also used for wood posts, the kits include stainless steel washers.

Series 272 Kits

Cable Length	1/8" cable PART NO.	3/16" cable PART NO.
30'	27230	27230-6
40'	27240	27240-6
50'	27250	27250-6
60'	27260	27260-6

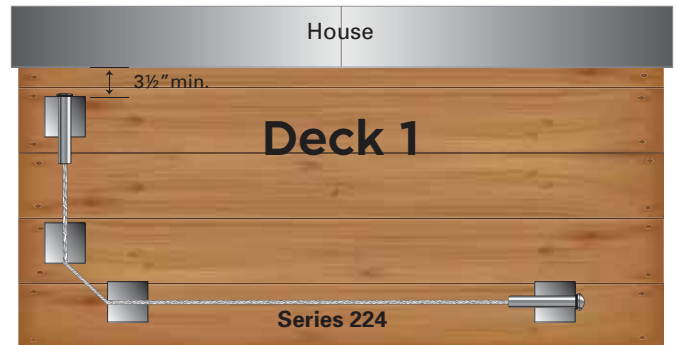

Depending on the size of your metal posts, the 224 Series fittings may extend beyond the width of the posts.

Series 224 Kits

Cable Length	1/8" cable PART NO.	3/16" cable PART NO.
30'	22430	22430-6
40'	22440	22440-6
50'	22450	22450-6

Tools needed for 224 Series:

- 5/32 drill bit if 1/8" cable, 7/32 if 3/16"
- 29/64 drill bit for Receiver and Pull-Lock® installation
- 3/16 Hex wrench for tensioning Receiver
- Cable cutting tool

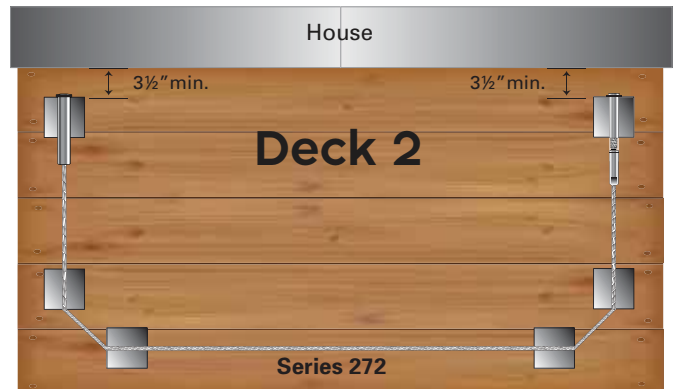

Tools needed for 272 Series:

- 5/32 drill bit if 1/8" cable, 7/32 if 3/16"
- 29/64 drill bit for Receiver and Push-Lock® installation
- 3/16 hex wrench for tensioning Receiver
- Cable cutting tool
- 7/16 wrench for tightening Push-Lock® Stud

Through-the-Post Mount

Cable Runs on a Pitch for 1-1/2" Posts

The cleanest approach to running cable on a pitch is to drill through both end both posts on the square (NOT at the angle of the stairs). No beveled washers necessary*. Only intermediate posts need to be drilled on the angle of the stairs.

*Not true for flat bar, which still needs to be drilled on the angle, requiring beveled washers.

For 1 1/2" metal square tube, use the 232 Series with 1/2" spacer

A 1/2" spacer (ordered separately) is installed on the back side of the post so the Receiver mounts flush to the face of the post. A 2" Pull-Lock® and spacer are installed through the other end.



Series 232 Kits

	1/8" cable	3/16" cable
Cable Length	1 1/2" or 2" Metal Post	1 1/2" or 2" Metal Post
	PART NO.	PART NO.
5'	23205	23205-6
10'	23210	23210-6
15'	23215	23215-6
20'	23220	23220-6
25'	23225	23225-6

1/2" Spacer

Order two spacers for each kit.

Order **SPC-R6-.500**

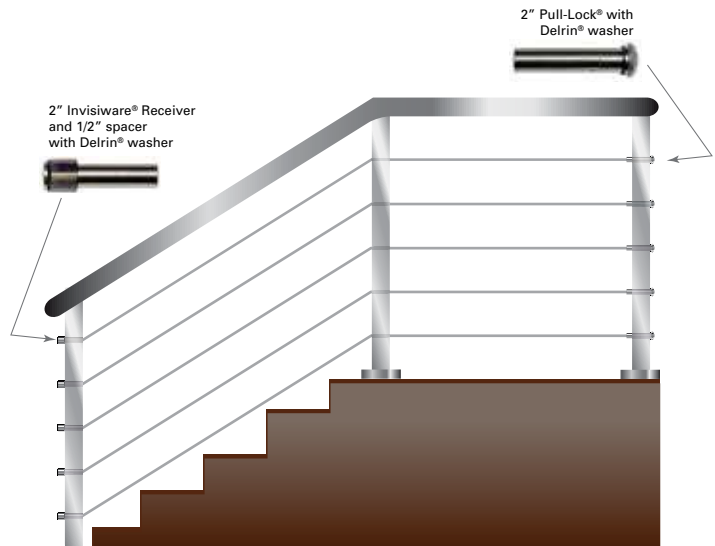
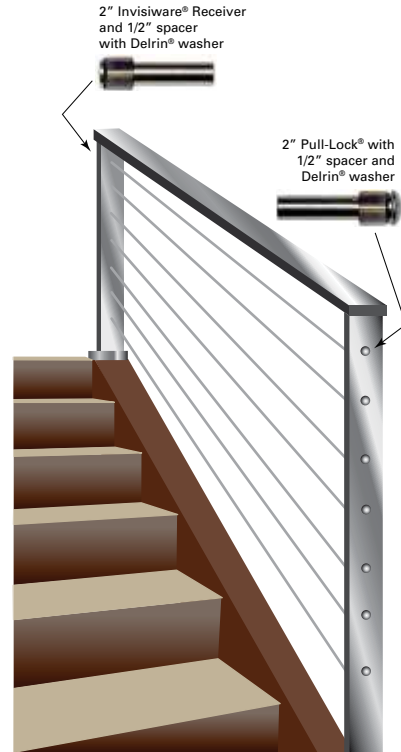

Tools needed for 232 Series:

5/32 drill bit if 1/8" cable, 7/32 if 3/16"

29/64 drill bit for Receiver and Pull-Lock® installation

3/16 hex wrench for tensioning Receiver

Cable cutting tool

Kit 212 Series Installation Instructions for 1½" Metal Posts

This kit may also be used for stairs or runs that exit the end posts on an angle.

A. Drill Posts

**Hole sizes through intermediate posts
and/or cable braces are:**

- 5/32" for 1/8" cable
- 7/32" for 3/16" cable

End posts are drilled through, using a 29/64" drill bit
for both the Receiver and Pull-Lock® fitting.

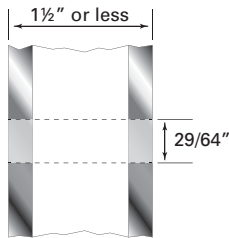

All holes should be burr-free.



B. Install Tensioning Terminal

1. Slip the Delrin® washer over the body of the Receiver and insert the Receiver into the post.
2. Start the threaded stud attached to the cable into the Receiver and turn 2 complete turns. This will thread about 1/3 of the stud into the Receiver.

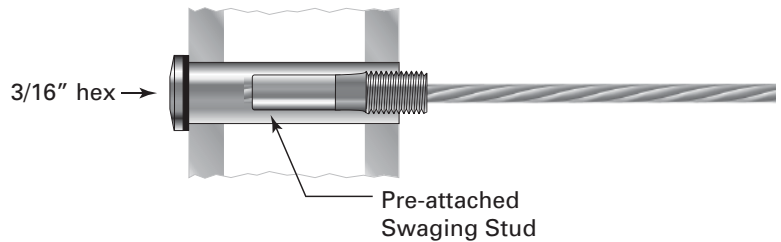

C. Feed Cable through Intermediate Posts

1. Feed the bare end of the cable through all your intermediate posts and through the end post where you will be installing the Pull-Lock® fitting.

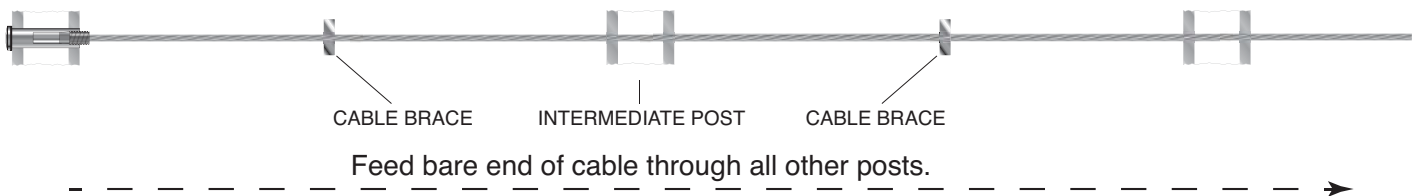

D. Feed/Crimp Cable through Corner Posts

This kit does not have enough tensioning take-up to properly negotiate a corner.
It is for straight runs only.

E. Install Swageless Terminal

1. Slip the Delrin® washer over the body of the Pull-Lock® fitting.

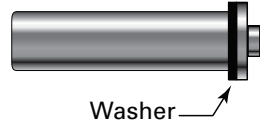

2. Rotate the Pull-Lock® fitting clockwise as you push it onto the cable. If the cable begins to “unravel,” you are rotating the fitting in the wrong direction.

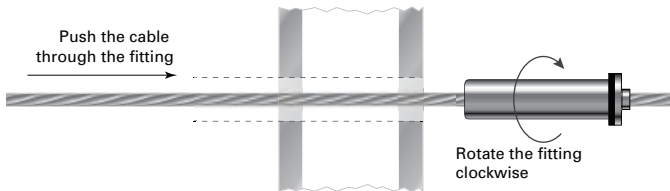

Note: If you have trouble inserting the cable into the fitting, it may be because the locking wedges have become stuck. This is not a defect! Here's what you can do to “free the wedges” —
 For Pull-Lock® or Push-Lock® fittings for 1/8” cable, using either a PL-KEY or 1/4” diameter bolt, insert the PL-KEY or bolt into the hole and press until the wedges move freely. Perform the same operation for a 3/16” Pull-Lock® or Push-Lock®, except use a 16d nail or another tool with 1/8” or smaller diameter. Anything larger than what is recommended can actually get stuck inside the fitting – NOT what you want!

3. Push the Pull-Lock® fitting along the cable and firmly into the hole in your post. While holding the Pull-Lock® fitting against the end post, pull the bare end of the cable to remove as much slack in the cable as possible.

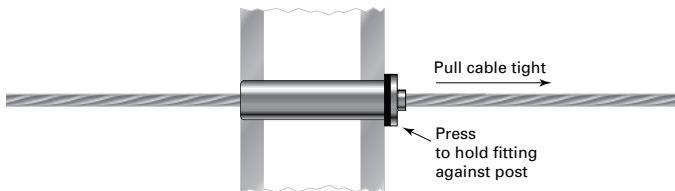

4. Cut the cable flush with the hole in the back of the fitting using a cut-off wheel.

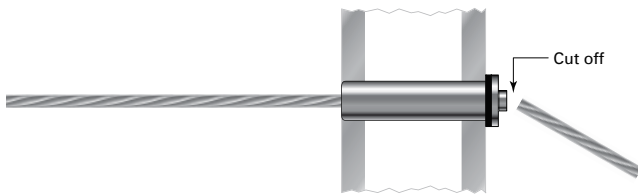

Cut-off Tool

Used to cut cable flush with the end of the Pull-Lock® fittings, and to cut excess threads off stud-type Receivers. Includes mandrel and two cut-off wheels. Order **CUT-OFF KIT**



5. Press the cap onto the lip of the Pull-Lock® fitting.

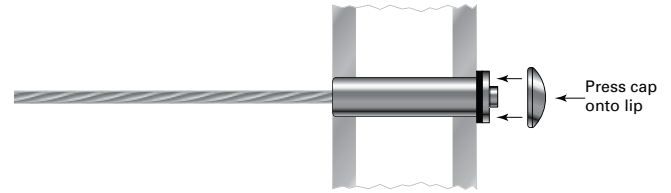

F. Tension Cables

1. Go to the other end and tension the cable by holding the cable securely to prevent it from turning while you turn the Receiver with a hex wrench. Be careful to protect the cable from damage while tensioning.

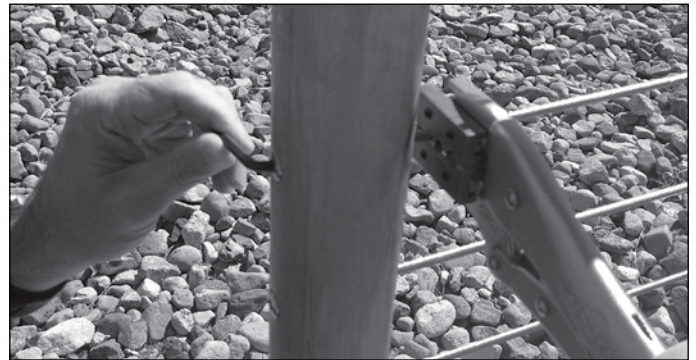

The swaging stud will be pulled into the Receiver by rotating the Receiver clockwise.

2. Tension all cables to desired amount in sequence, beginning with the center cables, moving up and down toward the top and bottom. As you tension each cable, give it a sharp pull downward mid-span to help set the wedges, then re-tension as necessary in the same sequence. Be aware that the cable may move as much as 3/16” toward the tensioning terminal as the wedges seat.

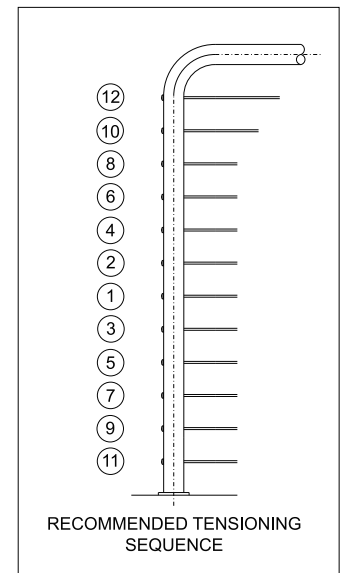

Kit 212 Series Stair Installation Instructions for 1-1/2" Metal Posts

A: Drill Posts

Hole size into end posts

Drill through both sides of both end posts.

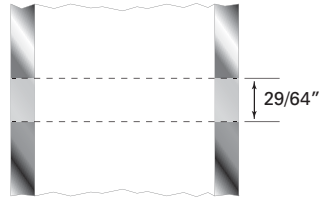

Intermediate posts are drilled on the angle.

Hole size for 1/8" dia. cable installation

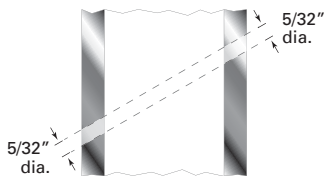

Hole size for 3/16" dia. cable installation

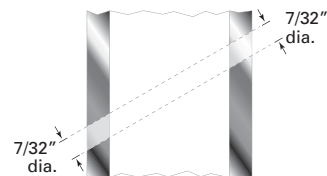

All holes should be burr-free.

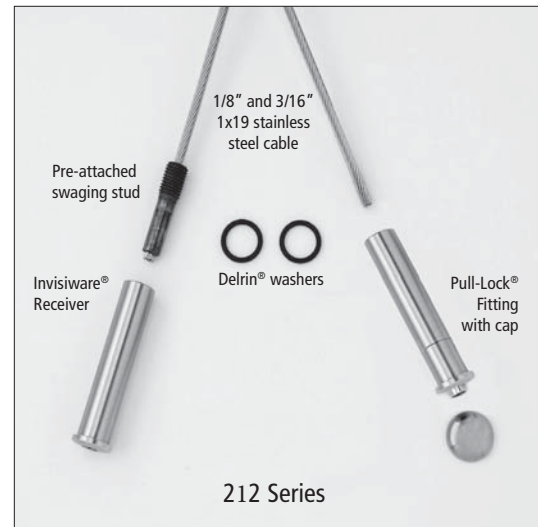

B. Install Tensioning Terminal

1. Grip the cable with cable gripping pliers approximately 3/16" away from the swaged stud and install Receiver over threads of stud about 5 to 6 turns. (Figure 1) Bend cable between stud and cable gripping pliers approximately 35-45 degrees. (Figure 2)
2. Remove stud from Receiver. Slide the Delrin® washer onto the Receiver first, then the spacer. Install Receiver into desired end post. Reinstall stud into Receiver at least 5 full turns. (Figure 3)

Figure 1

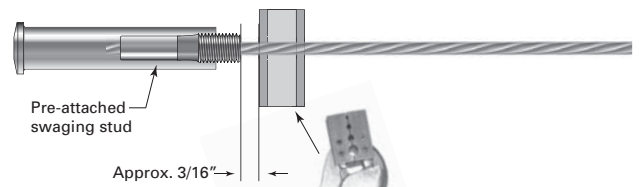

Figure 2

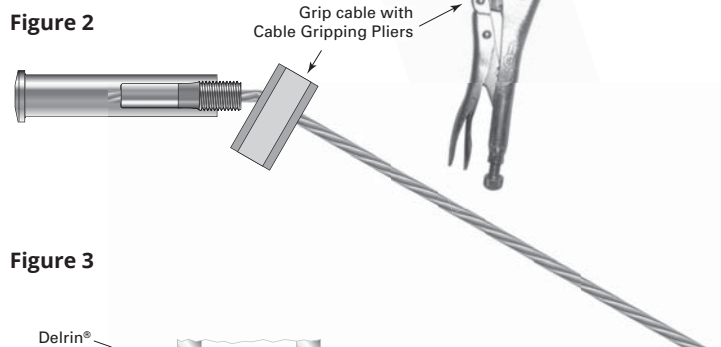
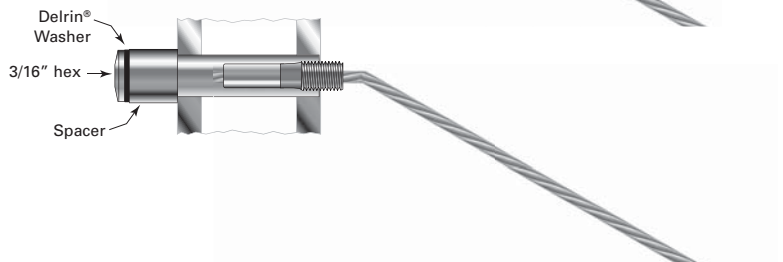

Figure 3



C. Feed Cable through Intermediate Posts

1. Feed the bare end of the cable through all your intermediate posts and through the end post where you will be installing the Pull-Lock® fitting.

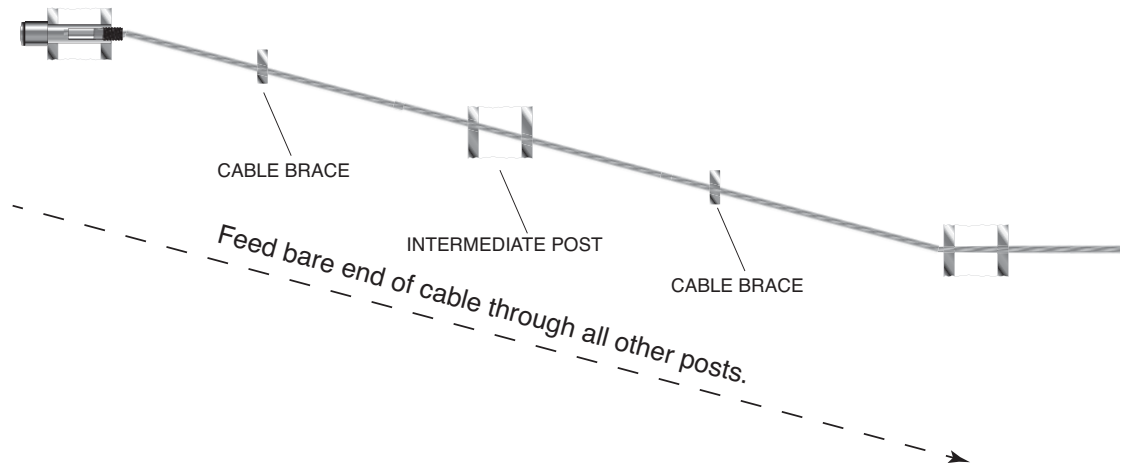

Figure 4

D. Feed/Crimp Cable through Corner Posts

As this section deals with passing cables through corners, which you will not be doing with stairs, please proceed to Section E.

E. Install Swageless Terminal

1. Slip the Delrin® washer and spacer over the body of the Pull-Lock® fitting. (Figure 5)

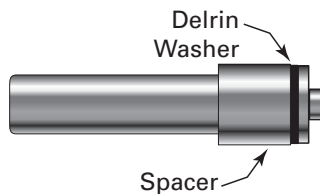

Figure 5

2. Rotate the Pull-Lock® fitting clockwise as you push it onto the cable. If the cable begins to "unravel," you are rotating the fitting in the wrong direction. (Figure 6)

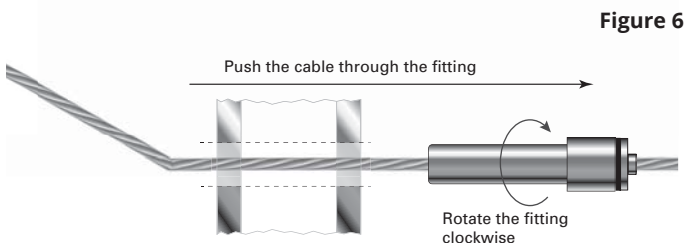

Figure 6

Note: If you have trouble inserting the cable into the fitting, it may be because the locking wedges have become stuck. This is not a defect! Here's what you can do to "free the wedges" — For Pull-Lock® or Push-Lock® fittings for 1/8" cable, using either a PL-KEY or 1/4" diameter bolt, insert the PL-KEY or bolt into the hole and press until the wedges move freely. Perform the same operation for a 3/16" Pull-Lock® or Push-Lock®, except use a 16d nail or another tool with 1/8" or smaller diameter. Anything larger than what is recommended can actually get stuck inside the fitting - NOT what you want!

3. Push the Pull-Lock® fitting along the cable and firmly into the hole in your post. Pull on the cable (cable gripping pliers are helpful for this) to create as much tension as possible as you seat the Pull-Lock® fitting into the hole. (Figure 7)

Make sure that the Receiver and stud on the opposite end are still seated in their pre-drilled hole (if not, seat them and repeat the process). The purpose of this is to make the cable as tight as possible prior to increasing tension on the cable by tensioning the Receiver.

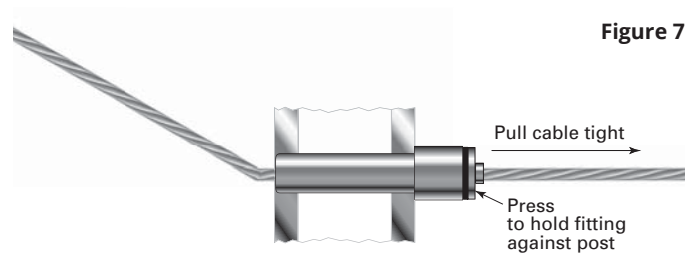
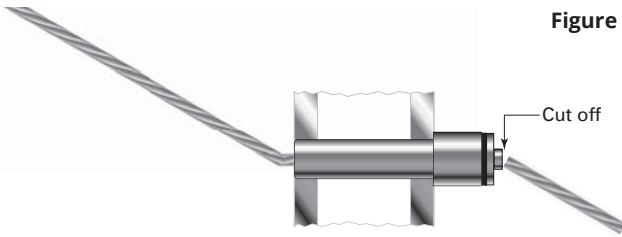

Figure 7

4. Cut the cable flush with the hole in the back of the fitting using a cut-off wheel. (Figure 8)

Figure 8



Cut-off Tool

Used to cut cable flush with the end of the Pull-Lock® fittings, and to cut excess threads off stud-type Receivers. Includes mandrel and two cut-off wheels. Order **CUT-OFF KIT**

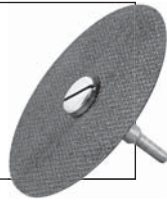

5. Press the cap onto the lip of the Pull-Lock® fitting. (Figure 9)

Figure 9

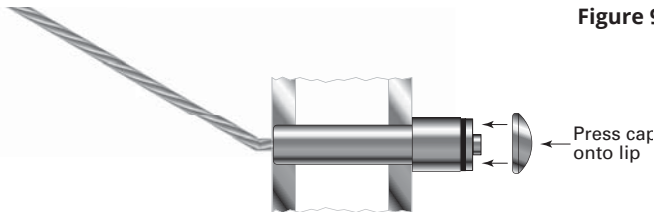

F. Tension Cables

1. Move back to the Receiver and stud end of cable and attach cable gripping pliers to the cable as close as is practical to the fittings without contacting the end post. (Figure 10)
Rotate the Receiver to create desired tension on the cable (you may have to move the cable gripping pliers several times to avoid contact with the end post).

Figure 10

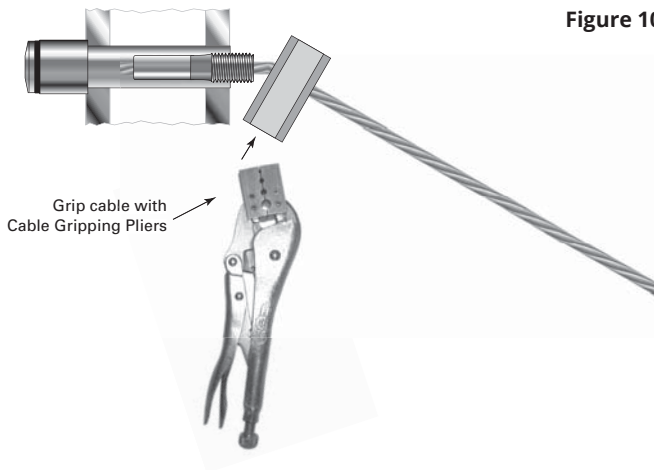

2. Tension all cables in sequence, beginning with the center cables, moving up and down toward the top and bottom. (Figure 11) As you tension each cable, give it a sharp pull downward mid-span to help set the wedges, then re-tension as necessary in the same sequence.

Figure 11

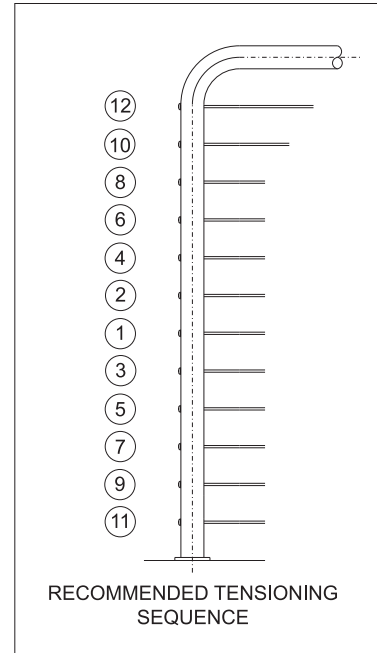

3. Move to Pull-Lock® end of the run and you are going to create a sharp bend in the cable where it exits post by placing a block of wood (for protection of the post) on the cable at the face of the post and striking it with a hammer. (Figure 12) This will create the sharp bend you are looking for.

Figure 12

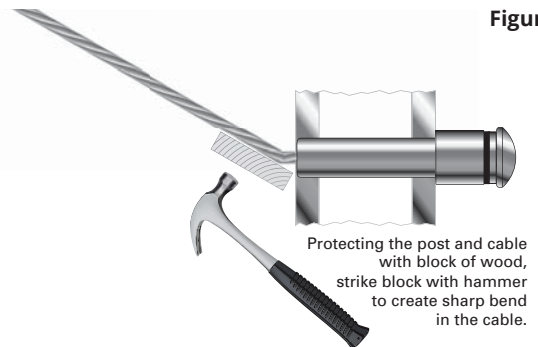

If tension has diminished slightly as a result of the bending of the cable, re-tension the Receiver as described back up to desired amount, making sure to prevent rotation of the cable by gripping it with cable gripping pliers while rotating Receiver.

Occasionally, the wedges may settle into the push lock body and be difficult to move. This may impede cable installation if they are not freed first. To free the wedges, do the following:

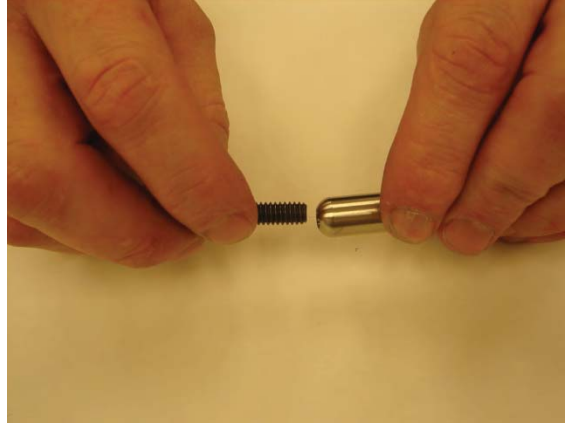

Push Lock for 1/8" cable: use a PL-Key tool or a 1/4" diameter fastener

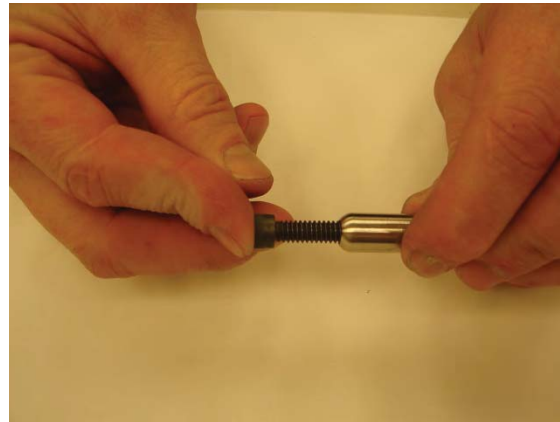

Insert the tool into the hole and press until the wedges move freely

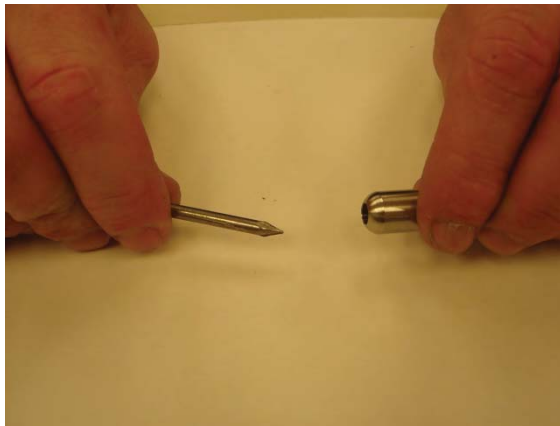

Push Lock for 3/16" cable: free the wedges using a 16d nail or another tool with a 1/8" or smaller diameter.