



Faux Iron Beam General Installation:

1. Acclimate beams in the room they are being installed in for minimum of 24 hours prior to install. Cut beams to desired length. Mark lines on ceiling with a chalk line, laser, or painters tape where beams will be installed (figure 1). NOTE: If using a 'U' beam with hollow interior, install wood blocking on ceiling at ends of beam and every 2-3 feet apart with screws (or heavy duty toggle bolts if a ceiling joist is not present). U beam slides over and is fastened into the blocking in addition to construction adhesive shown on following steps.
2. Apply a generous amount of PL Premium construction adhesive at the top and the ends of the beam (figure 2).
3. Press beam firmly against ceiling. Fasten beam to ceiling with screws into ceiling joists (figure 3a), countersinking screw heads. If ceiling joists are not present, use heavy duty toggle bolts instead of screws. If using toggle bolts, pre-drill hole through beam and ceiling for toggle bolts. Place toggle bolts through beam, then attach nuts. Punch nuts through pre-drilled holes in ceiling, then tighten bolts to secure (figure 3b on page 2).
4. Apply auto body or wood putty filler to conceal fasteners and touch up with flat black general purpose spray paint.

FIGURE 1

Mark lines on ceiling where beams will be installed

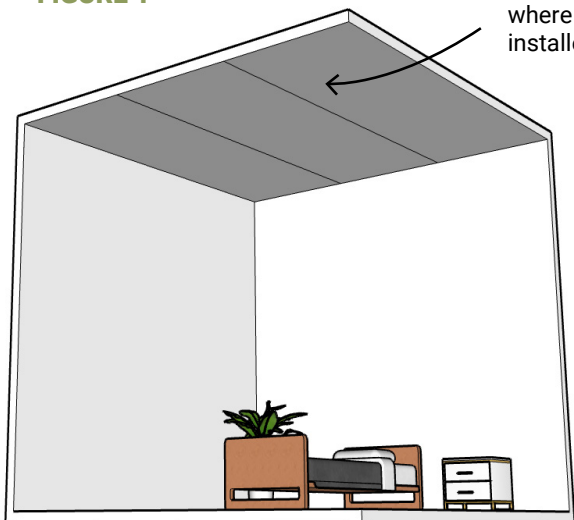

FIGURE 2

Apply a generous amount of PL Premium adhesive on the ends and the top of the beam

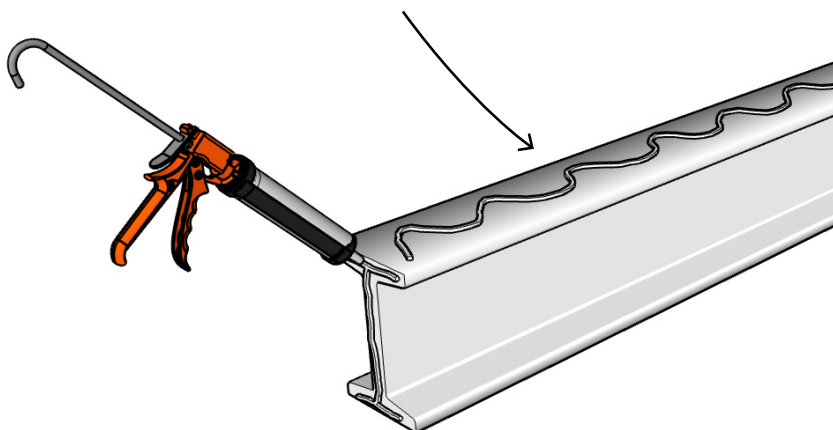
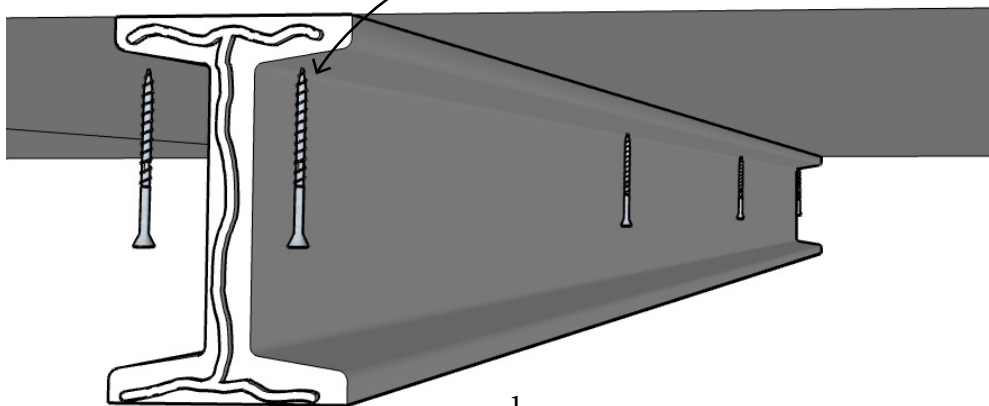

FIGURE 3a

Fasten beam to ceiling joists with screws, hitting every other joist, or approximately 3-4' apart.





IMPORTANT INSTALLATION AND PRODUCT NOTES:

- Always take appropriate safety precautions including use of protective eyewear, footwear, gloves, etc.
- Best practice is to install beams running perpendicular with the ceiling joists so screws can be used to fasten beams into wood.
- Polyurethane beams may expand and contract. PL Premium polyurethane adhesive must be used on ends of beam.
- Beams must be acclimated in the room they will be installed in for a minimum of 24 hours prior to installation.
- Heavy duty toggle bolts may be used instead of screws if joists are not present where beams are being installed.
- Forgecraft beams are manufactured from high density polyurethane and may be cut, trimmed, drilled, and fastened with woodworking tools.
- GENERAL DISCLAIMER: Consistent with decorative building product/industry norms, faux beams may require alterations to product and/or methods depending on site and other conditions. Installation instructions are intended to be general in nature. Installers should always use good discretion for the given site conditions and application.

TYPICAL TOGGLE BOLT INSTALLATION DETAIL (Figure 3B)

